

JOB NUMBER:  
1130  
DATE:  
09/08/11  
REVISIONS:



A New Expansion for:  
**TWENTY - TWO FIFTY INTERIORS**  
Building C - Sugar Land Town Square  
2250 Lone Star Drive  
Sugar Land, Texas

**JIM LAWLESS, AIA**  
Architect & Planner  
4610 Sweetwater Blvd  
Suite 200-C  
Sugar Land, Texas  
77478  
(281) 240-6101



THIS SEAL WAS AUTHORIZED  
THIS DATE: 02/08/11  
PROJECT: 113-110  
**H.M. McLEOD, P.E.**  
4975 KENNEDY ST. SUITE 30  
HOUSTON, TEXAS 77057  
OFFICE: (713) 961-8899  
FAX: (713) 961-8891  
CELL: (713) 968-1646  
From Registration:  
© 2011 H.M. McLeod, P.E.  
Drawings, written material, and design  
concepts shall not be used or  
reproduced, in whole or part in any  
form or format without prior written  
consent of H.M. McLeod, P.E.



DRAWING:  
FLOOR PLAN  
POWER  
**E-2**

**4 FLOOR PLAN - POWER**

SCALE: 1/4" = 1'-0"

- EXECUTE REMOVAL OF SLABS AND MASONRY BY SAW CUTTING. SECURE APPROVAL PRIOR TO ANY BORING OR SAWCUTTING OF THE FLOOR SLAB OR THE CONCRETE OF MASONRY WALLS AS WELL AS THE SHUTTING OFF OF ELECTRICAL TO THE PROJECT FROM THE PROJECT COORDINATOR OR PROPERTY MANAGER IN ADVANCE, NO EXCEPTIONS.
- LANDLORD'S RECOMMENDED SUBCONTRACTOR FOR TENANT'S FIRE ALARM IS FIRETRON, BUT FIRETRON IS NOT REQUIRED FOR INTERIOR WORK.

**3 NOTES**

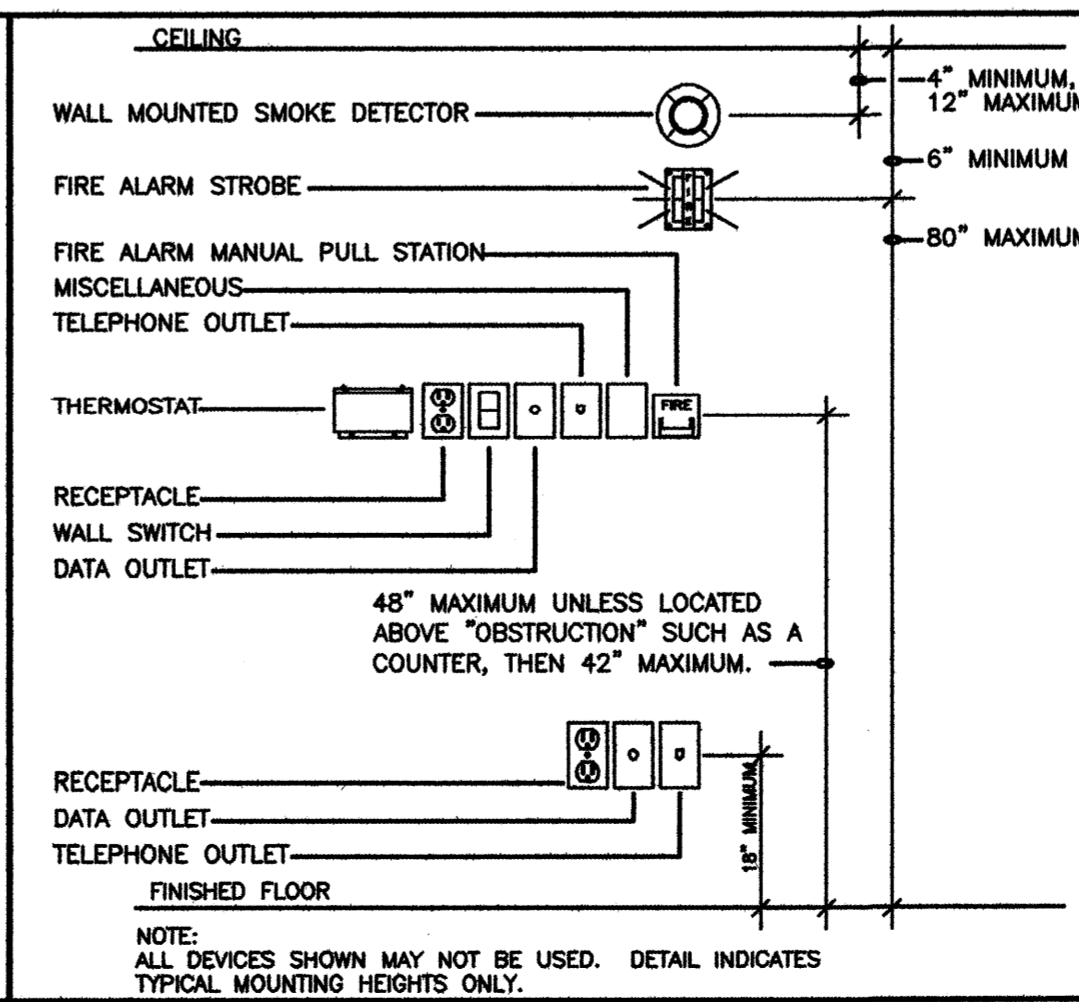

**2 A.D.A. DEVICE MOUNTING**

ABV	ABOVE	GAL	GALLONS
AFF	ABOVE FINISHED FLOOR	HW	HOT WATER
AHU	AIR HANDLING UNIT	IE	INVERT ELEVATION
ARCH	ARCHITECTURAL	KW	KILOWATTS
BOD	BOTTOM OF DUCT	LAV	LAVATORY
BLDG	BUILDING	MAX	MAXIMUM
CI	CAST IRON	MECH	MECHANICAL
CL	CENTER LINE	MIN	MINIMUM
CO	CLEANOUT	MVD	MANUAL VOLUME DAMPER
COG	CLEANOUT AT GRADE	MTD	MOUNTED
CONC	CONCRETE	NIC	NOT IN CONTRACT
CONN	CONNECTION	NK	NECK
CONT	CONTINUATION	OA	OUTSIDE AIR
CW	DOMESTIC COLD WATER	OSD	OPPOSED BLADE DAMPER
DN	DOWN	PSI	POUNDS PER SQUARE INCH
DIA	DIAMETER	PRV	PRESSURE REDUCING VALVE
DWG	DRAWING	RA	RETURN AIR
ELEC	ELECTRICAL	RD	ROOF DRAIN
EF	EXHAUST FAN	SA	SUPPLY AIR
EMH	ELECTRIC WATER HEATER	SF	SUPPLY FAN
FV	FIRE DEPARTMENT VALVE	SP	STATIC PRESSURE
FCO	FLOOR CLEANOUT	SPEC	SPECIFICATIONS
GALV	GALVANIZED	TYP	TYPICAL

**1 GENERAL ABBREVIATIONS**