

ISSUE
11-30-10 ISSUED FOR PERMIT

HARRELL
ARCHITECTS, LP
927E KOW Fwy., #200
Houston, Texas 77024
Tel: 713.722.7071
Fax: 713.722.7072

CONSULTANTS
HOBLE & ASSOCIATES
MEP Engineers

PROJECT NAME
GUADALUPANA RESTAURANT



PROJECT ADDRESS
20 WATERWAY
THE WOODLANDS, TEXAS

PROJECT NUMBER
SHEET NAME
PLUMBING DETAILS
SHEET NUMBER

P3.00

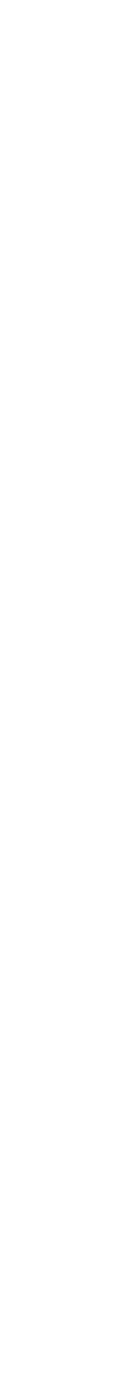
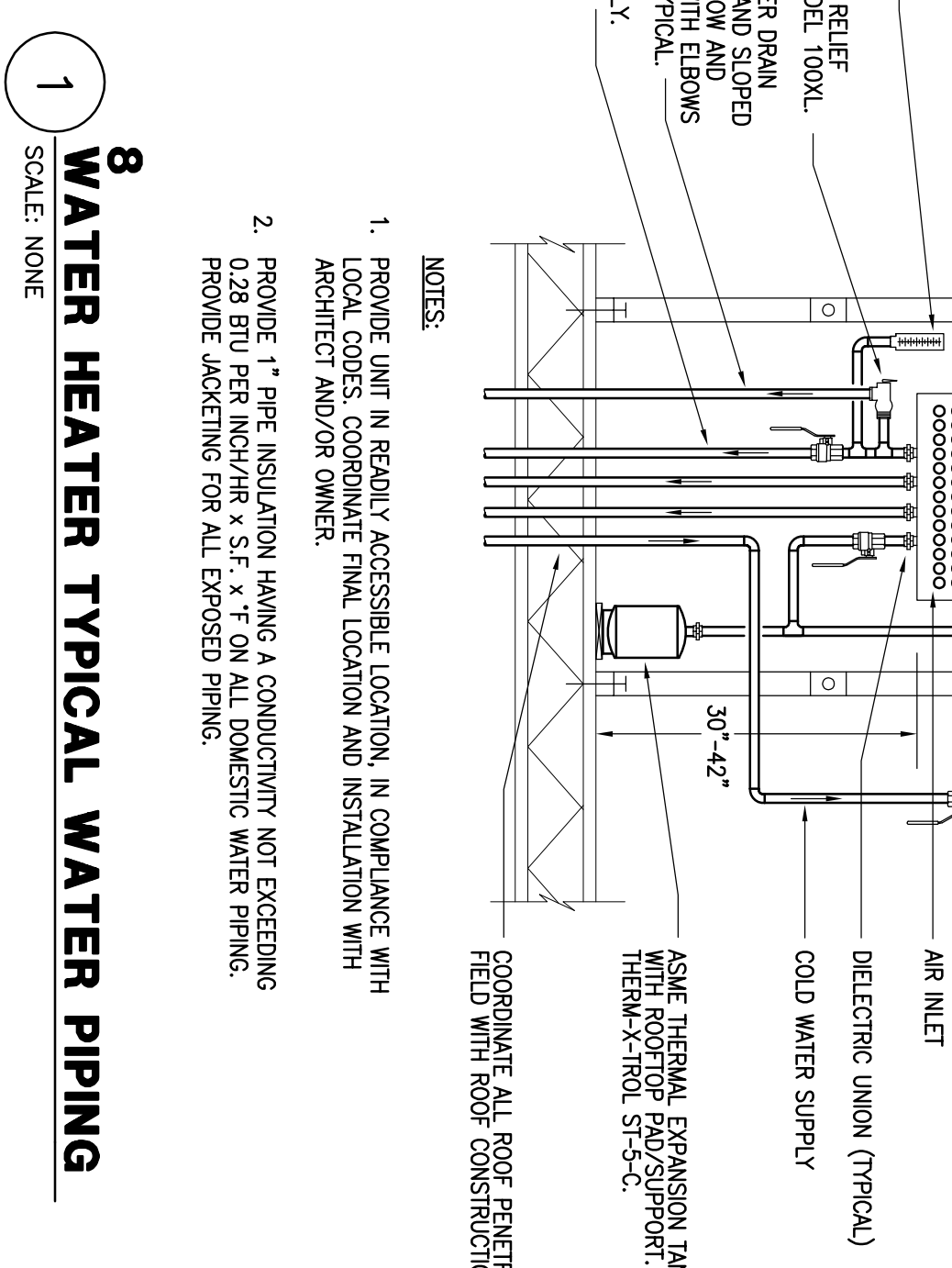
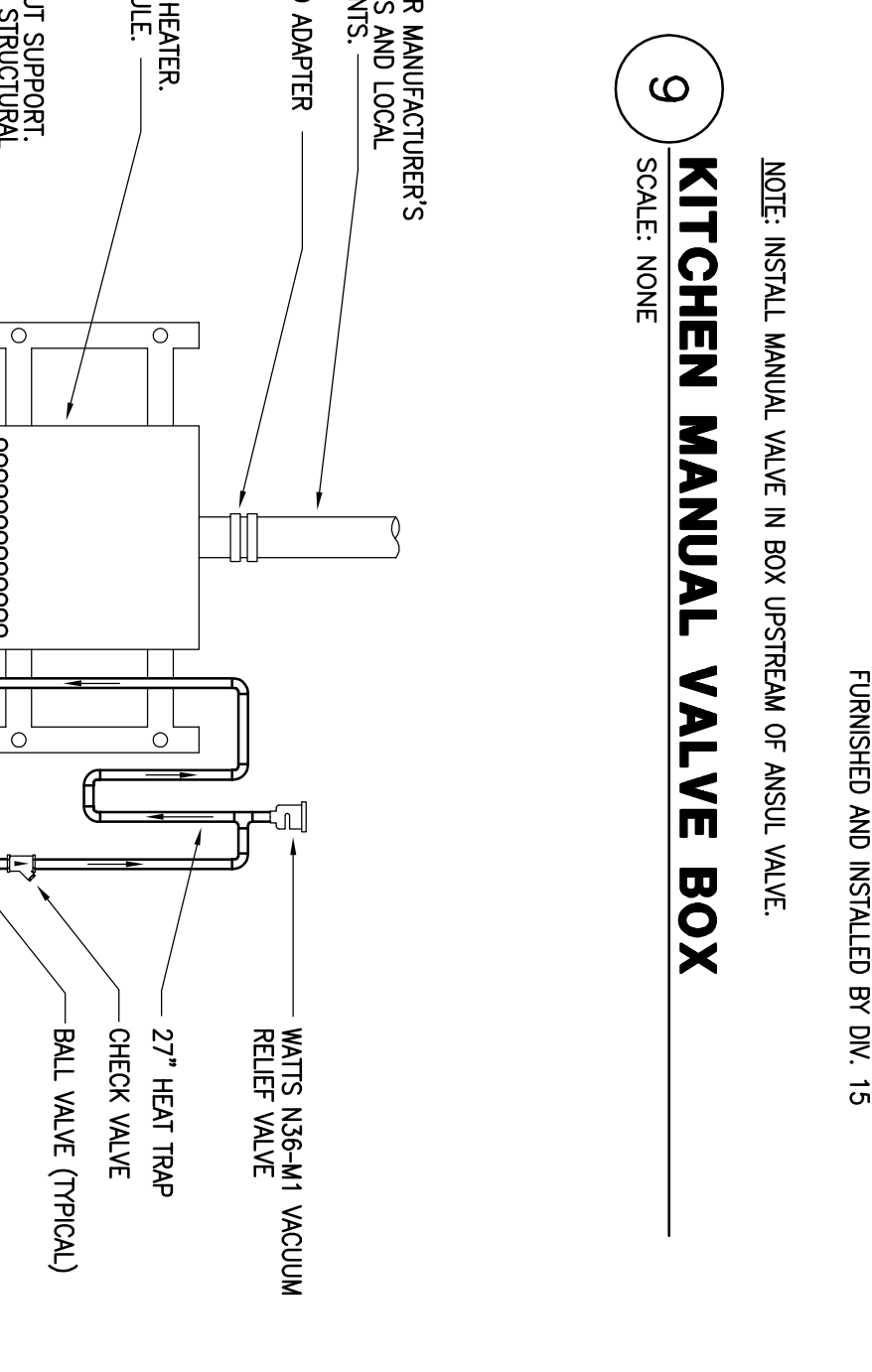
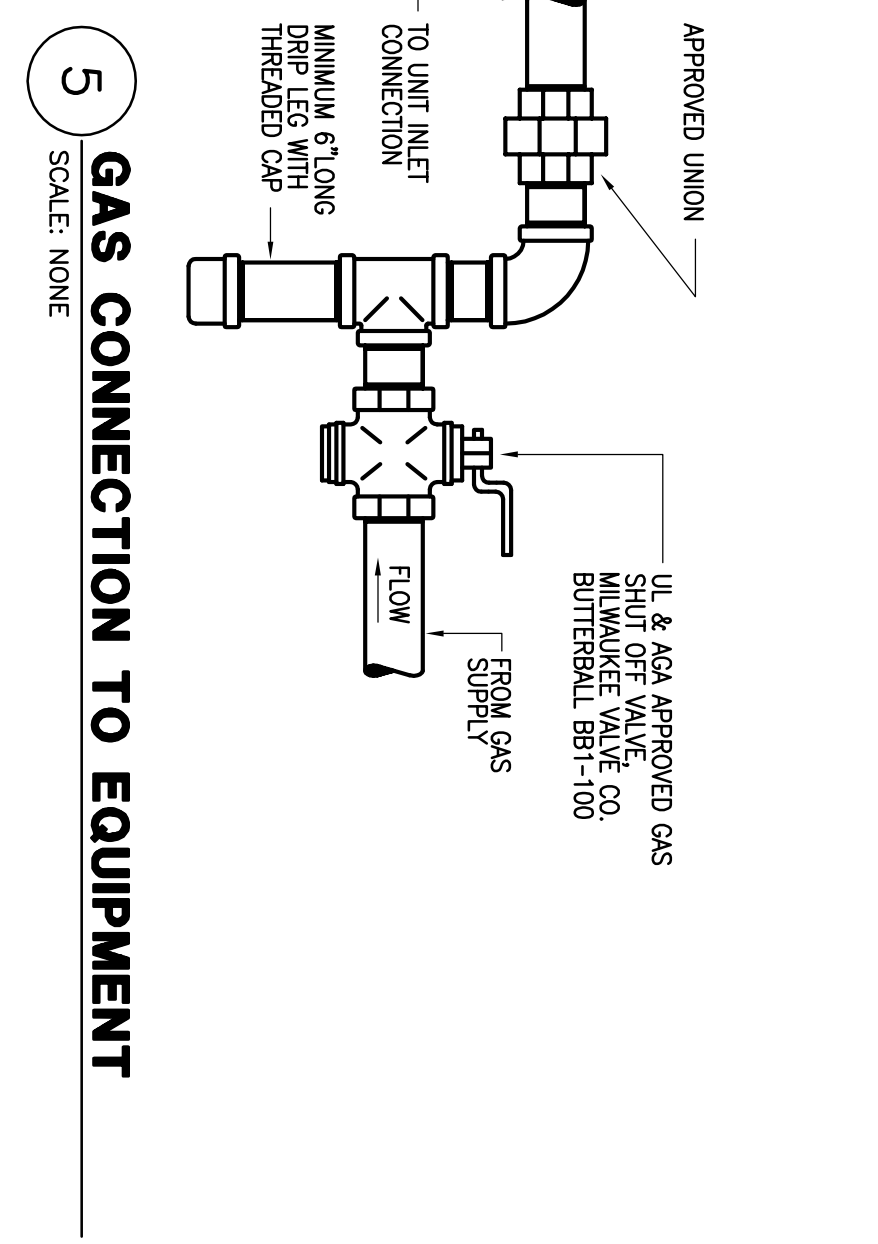
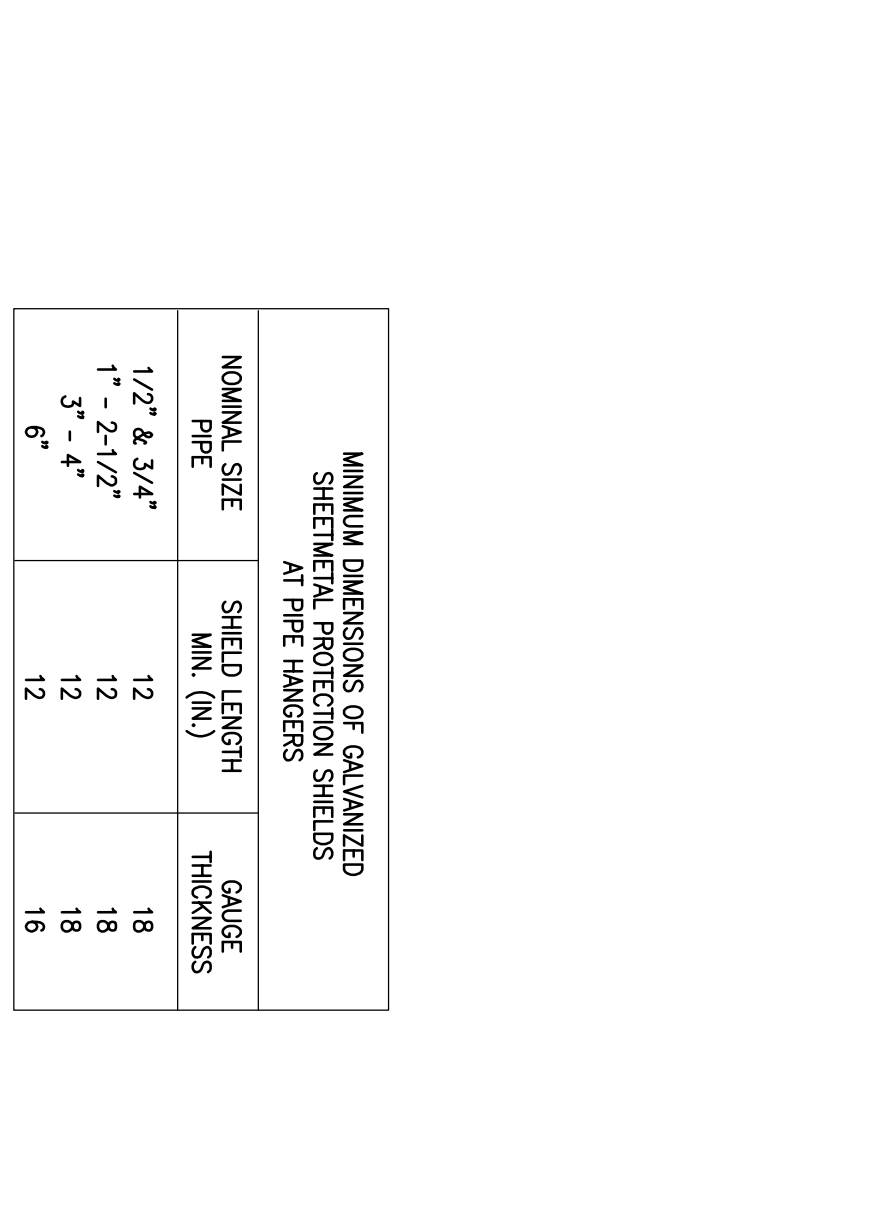
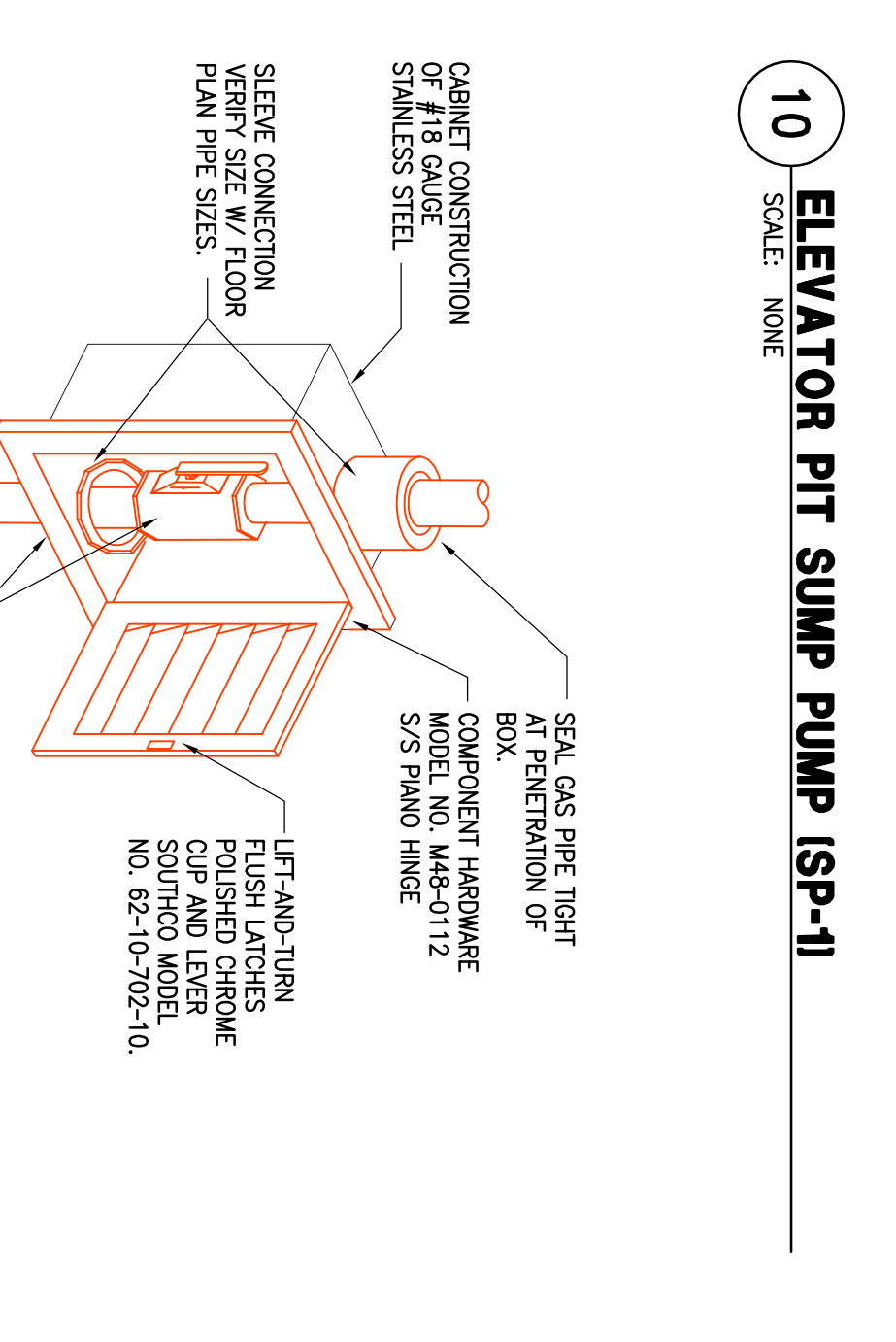
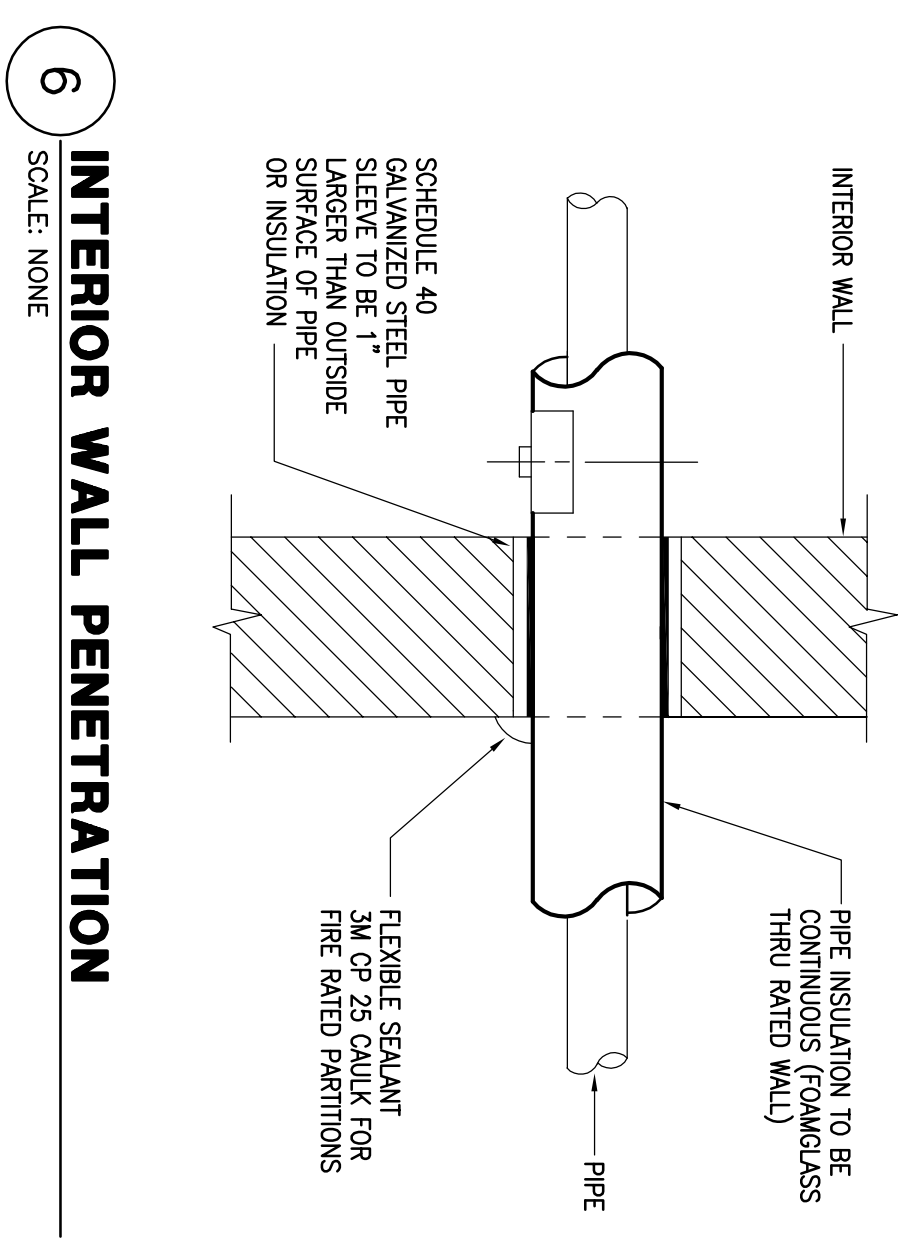
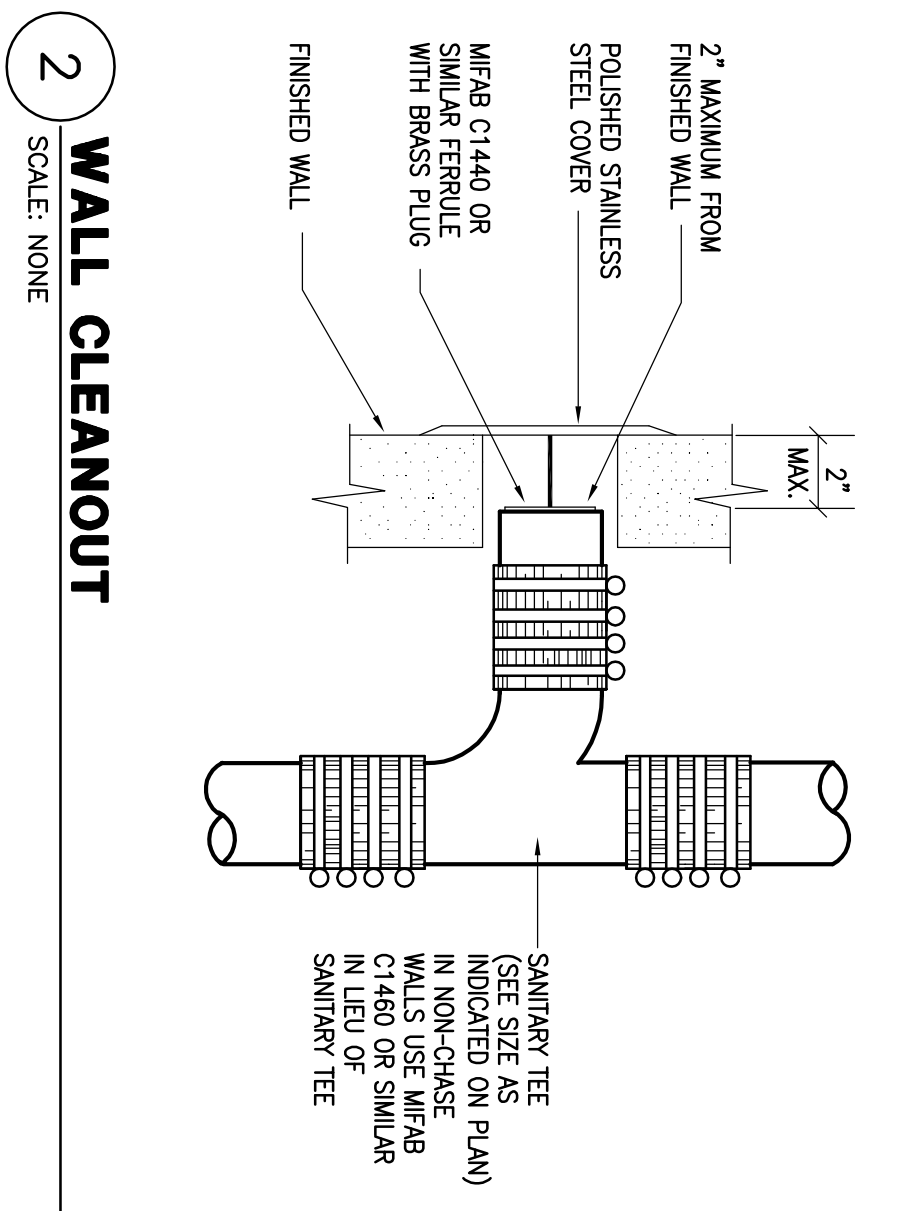
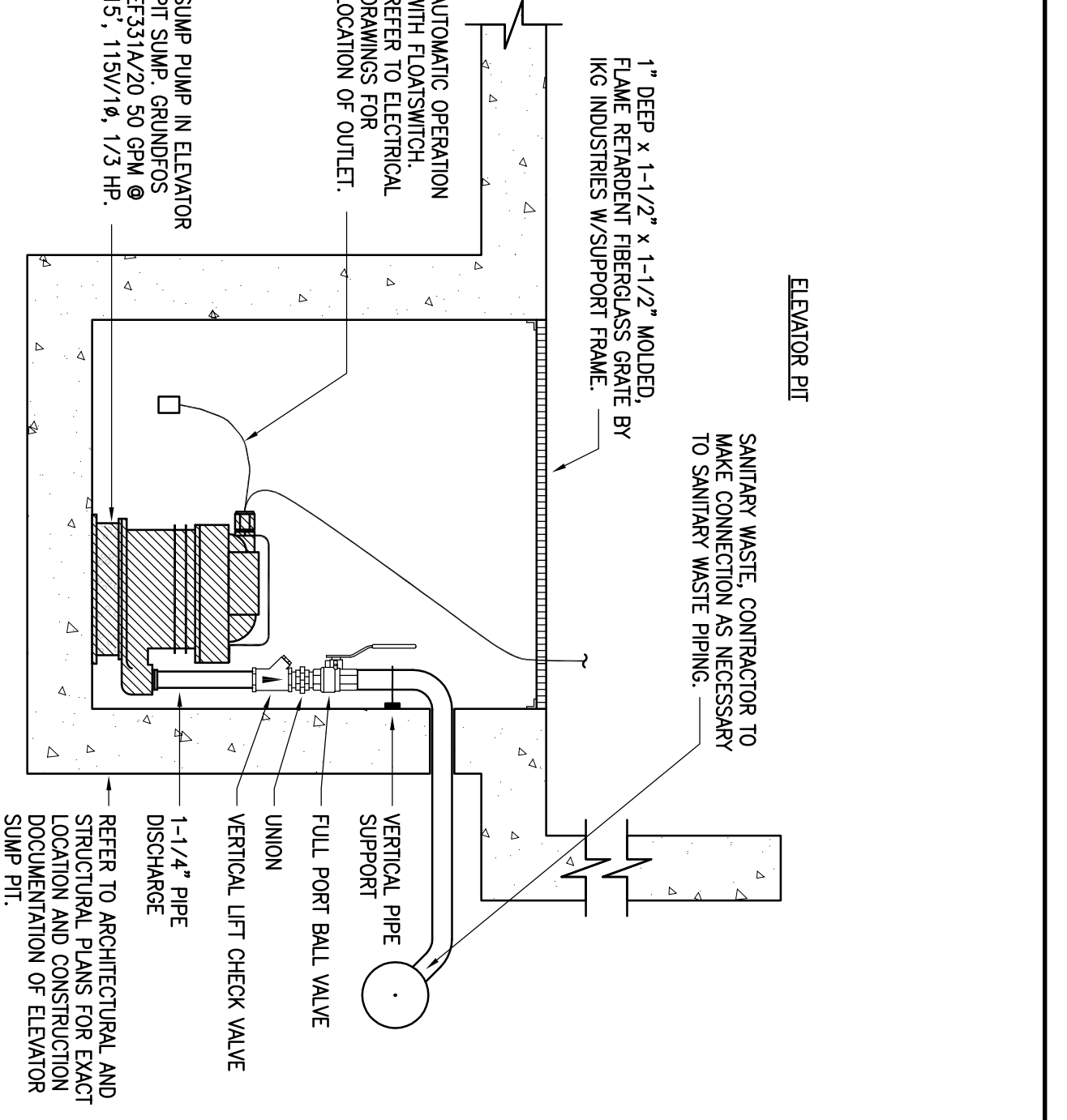
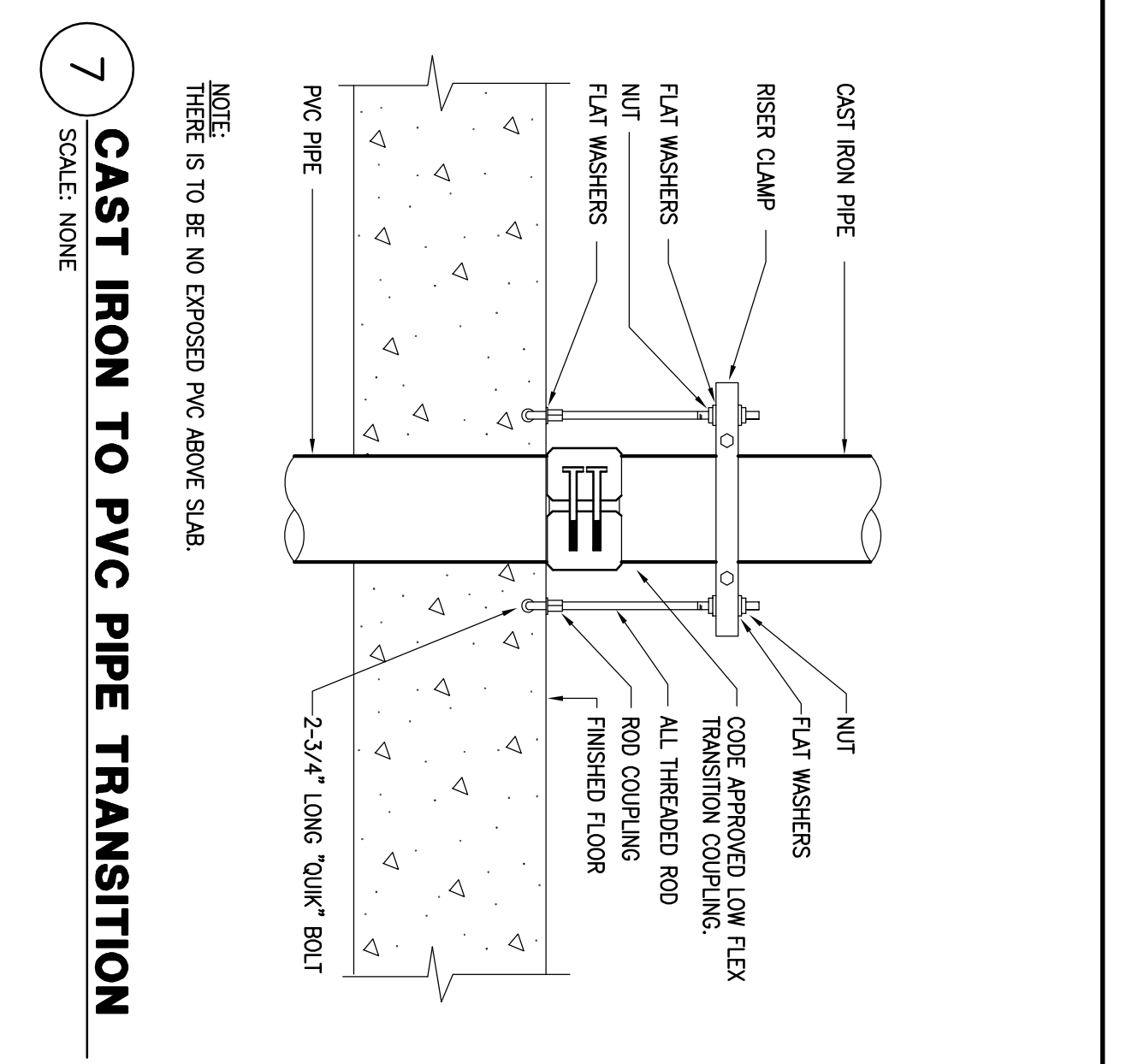
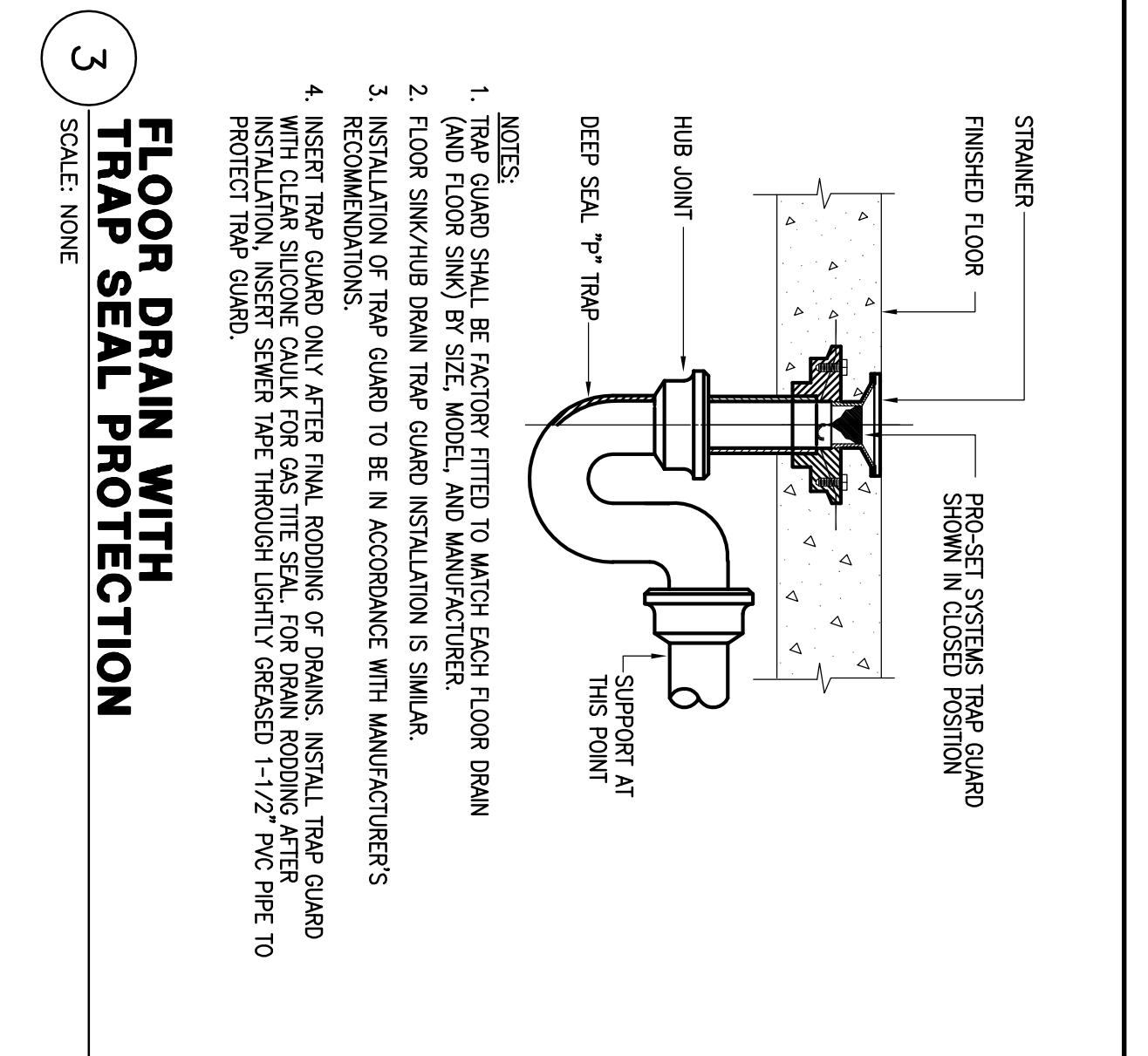

Hoble & Associates, Inc.
Civil/Structural Engineering - Texas Reg. 15443
Mechanical Engineering - Texas Reg. 15443
Houston, Texas 77071 (713) 962-1371
www.hobleandassociates.com