

- B. There shall be no sharp or abrasive surfaces under lavatories.
- TAS SECTIONS 4.19.5, 4.27.4 – FAUCETS
- A. Controls shall be operable with one hand and shall not require tight grasping, pinching, or twisting of the wrist.
- B. The force required to activate controls shall be no greater than 5 lbf.
- C. Lever-operated, push-type, and electronically controlled mechanisms are examples of acceptable designs.
- D. If self-closing valves are used the faucet shall remain open for at least 10 seconds.

TAS SECTION 4.19.6 – MIRRORS (REFERENCE DETAIL 12.5.1)

- A. Mirrors shall be mounted with the bottom edge of the reflecting surface 40" maximum above the finished floor.

4.20 BATHTUBS

TAS SECTION 4.20.2 – FLOOR SPACE

- A. Clear floor space shall be provided in front of bathtubs as follows: 30" wide x 60" long beside the bathtub for side approach; 48" wide x 60" long beside the bathtub for front approach with seat at head of tub – 30" wide x 75" long beside tub

TAS SECTION 4.20.3 – SEAT

- A. An in-tub seat or a seat at the head end of the tub shall be provided. Seats shall be mounted securely and shall not slip during use.

TAS SECTIONS 4.20.4 – GRAB BARS

- A. Heights permitted:
- With in Tub Seat: Control wall: 24" long minimum, from outside wall, 33–36" above floor. Back wall: 2 bars, 24" long minimum, 12" maximum from foot end, 24" maximum from head end; one 33–36" above floor, one 9" above the tub. Head wall: 12" minimum, from outside wall, 33–36" above floor.
 - With Seat at Head of Tub: Control wall: 24" long minimum, from outside wall, 33–36" above floor. Back wall: 2 bars, 48" long minimum, 12" maximum from foot end, 15" maximum from head end; one 33–36" above floor, one 9" above the tub. Head wall: none.

TAS SECTION 4.20.6 – SHOWER UNIT

- A. A shower spray unit with a hose at least 60" long shall be provided.

4.21 SHOWER STALLS

TAS SECTION 4.21.2 – SIZE AND CLEARANCES

- A. Shower stalls shall be either 36"x36" clear inside dimension or 30" min. x 60" min. clear inside dimension.

TAS SECTIONS 4.21.3 – SEAT

- A. Seat is required in 36"x 36" stalls, and shall have the following features:
- Shall be 17"–19" above bathroom floor.
 - Shall extend the full depth of the stall.
 - Shall be located on the wall opposite control wall.
 - Maximum space between wall and seat edge shall be 1–1/2".
 - Shall project 16" maximum into stall width, except at the rear 15" maximum of the stall, where the seat may project 23".

TAS SECTIONS 4.21.4 – GRAB BARS

- A. Grab bars shall be mounted 33–36" above floor.

TAS SECTIONS 4.21.5 – CONTROLS

- A. All shower controls shall be located 38" minimum and 48" maximum above the floor.

TAS SECTION 4.21.6 – SHOWER UNIT

- A. A shower spray unit with a hose at least 60" long that can be used both as a fixed shower head and as a hand held shower shall be provided. The mounting device shall comply with the requirements for Forward Reach.

TAS SECTIONS 4.21.7 – CURBS

- A. If provided, curbs on transfer showers shall be no higher than 1/2" roll-in showers shall not have curbs.

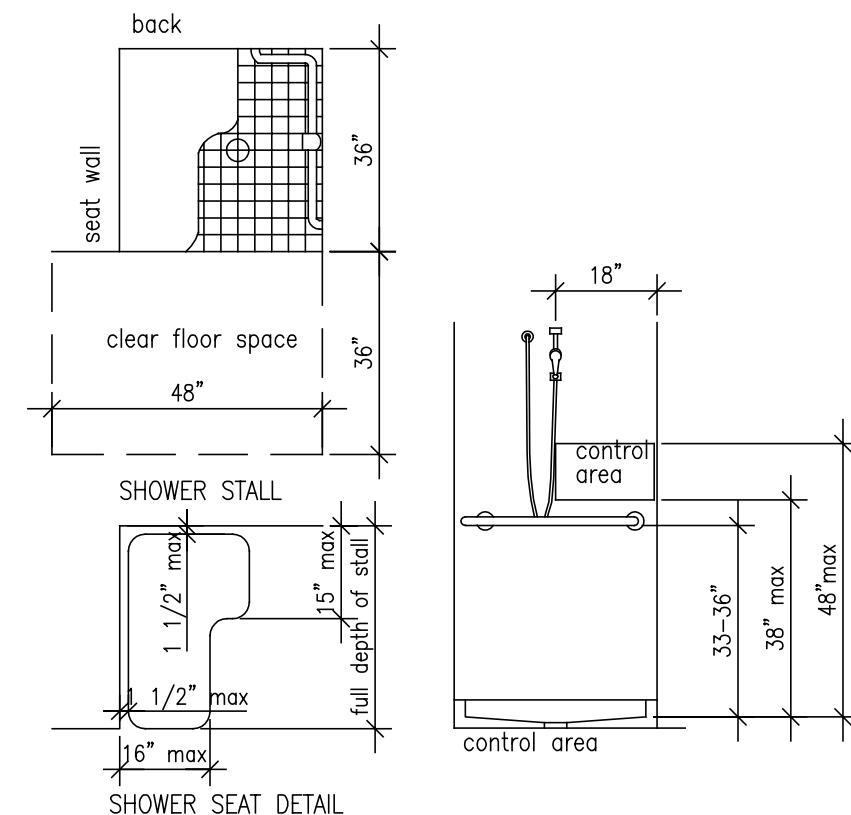

4.22 TOILET ROOMS

TAS SECTIONS 4.22.2 – DOORS

- A. All doors to accessible toilet rooms shall comply with 4.13. Doors shall not swing into clear floor space required for any fixture. Clear floor turning space may overlap door swings.

TAS SECTIONS 4.22.3 – CLEAR FLOOR SPACE

- A. The accessible fixtures and controls required in 4.22.4, 4.22.5, 4.22.6, 4.22.7 shall be on an accessible route. An unobstructed turning space complying with 4.2.3 shall be provided within an accessible toilet room. The clear floor space at fixtures and controls, the accessible route, and the turning space may overlap, however, the only turning space provided shall not be located within a stall.

TAS SECTIONS 4.22.4 – WATER CLOSETS

- A. If toilet stalls are provided, then at least one shall be a standard toilet stall complying with 4.17, where 6 or more stalls are provided in addition to the stall complying with 4.17.3, at least one stall 36" wide with an outward swinging, self-closing door and parallel grab bars shall be provided. Water closets in such stalls shall comply with 4.16.

TAS SECTIONS 4.22.5 – URINALS

- A. If urinals are provided, then at least one shall comply with 4.18.

TAS SECTIONS 4.22.6 – LAVATORIES AND MIRRORS

- A. If lavatories and mirrors are provided, then at least one of each shall comply with 4.19. Accessible lavatories and mirrors shall not be located within toilet stalls unless other accessible lavatories and mirrors are provided in the toilet room.

TAS SECTIONS 4.22.7 – CONTROLS AND DISPENSERS

- A. If controls, dispensers, receptacles, or other equipment are provided, then at least one of each shall be on an accessible route and shall comply with 4.27 – (Controls & Operating Mechanisms).

4.23 – BATHROOMS, BATHING FACILITIES, AND SHOWER ROOMS

TAS SECTION 4.23.8 – BATHING AND SHOWER FACILITIES

- A. If tubs and showers are provided, then at least one accessible tub that complies with 4.20 or at least one accessible shower that complies with 4.21 shall be provided.

4.24 – SINKS

TAS SECTION 4.24.3 – HEIGHT (REFERENCE DETAIL 12.5.1)

- A. Sinks shall be mounted with the rim or counter surface no higher than 34" above the finished floor.

TAS SECTIONS 4.24.3 – KNEE CLEARANCE (REFERENCE DETAIL 12.5.1)

- A. Knee clearance of 27" high minimum, 30" wide minimum, and 19" deep minimum shall be provided underneath sinks.

TAS SECTION 4.24.4 – DEPTH

- A. Each sink shall be a maximum of 6–1/2" deep.

TAS SECTION 4.24.6 – EXPOSED PIPES AND SURFACES

- A. Hot water and drain pipes under sinks shall be insulated or otherwise configured to protect against contact.

- B. There shall be no sharp or abrasive surfaces under sinks.

TAS SECTION 4.24.7, 4.27.4 – FAUCETS

- A. Controls shall be operable with one hand and shall not require tight grasping, pinching, or twisting of the wrist.
- B. The force required to activate controls shall be no greater than 5 lbf.
- C. Lever-operated, push-type, and electronically controlled mechanisms are examples of acceptable designs.

- D. If self-closing valves are used the faucet shall remain open for at least 10 seconds.

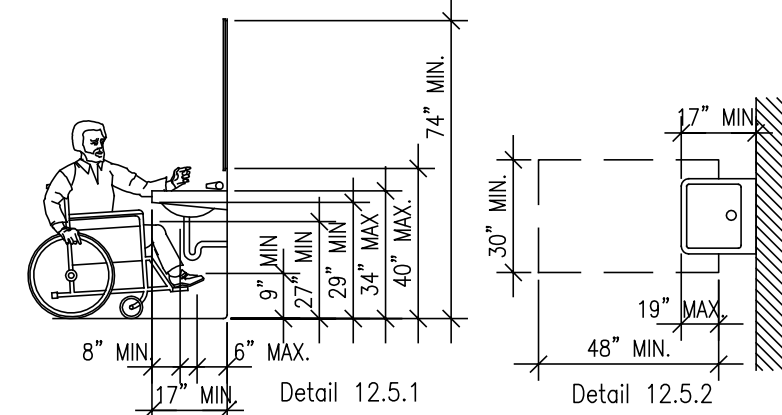

4.25 – STORAGE

TAS SECTION 4.25.1 – DEPTH (REFERENCE DETAIL 14.1)

- A. Storage areas may be 36" in depth or less. If more than 36" in depth then area must allow 60" diameter of clear floor space for turning.

TAS SECTION 4.25.2 – CLEAR FLOOR SPACE: (REFERENCE DETAIL 14.2)

- A. Where a forward reach is required, accessible storage spaces shall be 48" maximum and 15" minimum above the floor. If the forward reach is over an obstruction (with knee space equal to or greater than reach distance) 20"–25" deep, the maximum height shall be 44", if the obstruction is less than 20", maximum height shall be 48".

- B. Where a side reach is provided, accessible storage spaces shall be 54" maximum and 9" minimum above the floor. Maximum height shall be 46" for side reach over an obstruction 34" maximum high and 24" maximum deep.

- C. Clothes rods or shelves shall be a maximum 54" above floor where a side reach is required.

- D. Where the distance from the wheelchair to the clothes rod or shelf exceeds 10" (as at closets with inaccessible doors) the following criteria shall be met:

- Shelves: Reach: 21" maximum; height: 48" maximum, 9" minimum.
- Clothes rods: reach 21" maximum; height: 48" maximum.

TAS SECTIONS 4.25.4, 4.27.4 – HARDWARE

- A. Hardware for accessible storage facilities shall be operable with one hand and shall not require tight grasping, pinching, or twisting of the wrist.

- B. The force required to activate the hardware shall be no greater than 5 lbf.

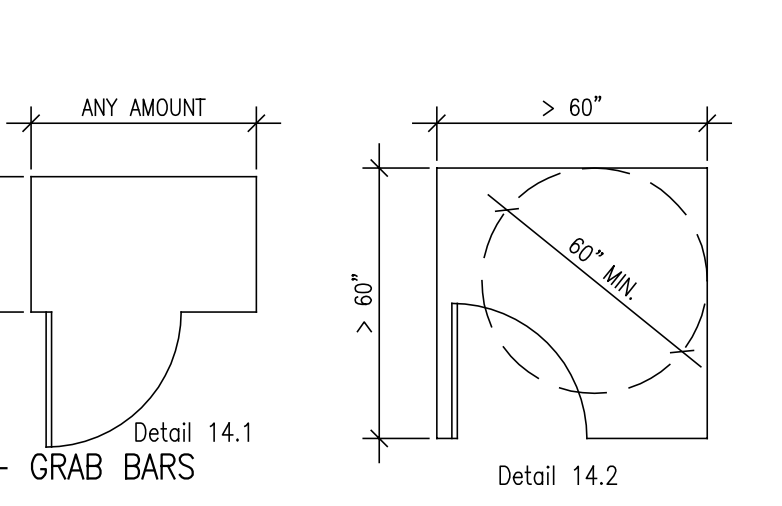
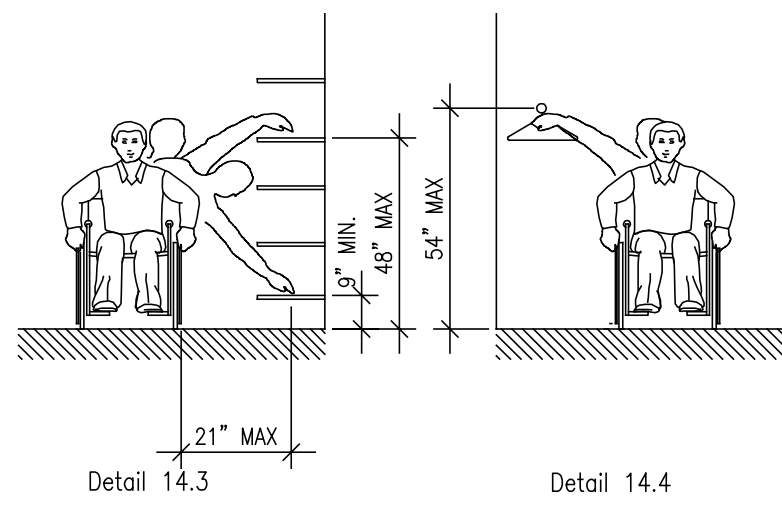

4.26 – GRAB BARS

TAS SECTION 4.26.2 – SIZE AND SPACING

- A. Diameter or width of gripping surface shall be 1–1/4" to 1–1/2", or the shape shall provide an equivalent gripping surface.

- The space between grab bars and adjacent walls shall be 1–1/2"

TAS SECTION 4.26.3 – STRUCTURAL STRENGTH

- A. Grab bars and mounting devices shall meet the following requirements:
- Bending stress induced by maximum bending moment from application of 250 lbf shall be less than allowable bending stress for material used.
 - Shear stress induced by application of 250 lbf shall be less than allowable shear stress for material used. If connection between grab bar and mounting bracket is considered to be fully restrained, then direct and torsional shear stresses shall be totaled for the combined shear stress, which shall not exceed the allowable shear stress.
 - Shear force induced in a fastener or mounting device from application of 250 lbf shall be less than allowable lateral load of either the fastener or mounting device or the supporting structure, whichever is the smaller allowable load.
 - Tensile force induced in a fastener by a direct tension force of 250 lbf plus the maximum moment from the application of 250 lbf shall be less than the allowable withdrawal load between the fastener and the supporting structure.
 - Grab bars shall not rotate within their fittings.

TAS SECTION 4.26.4 – ELIMINATING HAZARDS

- A. Grab bars and adjacent wall surfaces shall be free of sharp or abrasive surfaces.
- B. Edges shall have a radius of 1/8" minimum.

4.27 – CONTROLS AND OPERATING MECHANISMS

TAS SECTION 4.27.3 – HEIGHT (refer to detail 16.3)

- A. Front approach – 48" max. to 15" min.
- B. Side approach – 54" max. to 9" min., except per below.
- C. Electrical & communication system receptacles shall be mounted no less than 15" above the floor.

4.28 – ALARMS

TAS SECTION 4.28.1 – GENERAL

- A. When required, visual alarms shall be provided in each of the following areas, as a minimum: restrooms and any other general usage areas (e.g., meeting rooms), hallways, lobbies, and any other area for common use.

TAS SECTION 4.28.2 – AUDIBLE ALARMS

- A. If provided, audible alarms shall produce a sound that exceeds the prevailing equivalent sound level in the room or space by at least 15 dba or exceeds any maximum sound level with a duration of 60 seconds by 5 dba, whichever is louder.
- B. Sound levels for alarm signals shall not exceed 120 dba.

TAS SECTION 4.28.3 – VISUAL ALARMS

- A. Visual alarm signal appliances shall be integrated into the building or facility alarm system. If single station audible alarms are provided then single station visual alarm signals shall be provided.

Visual Alarm appliances shall have the following features:

- The lamp shall be a xenon strobe type or equivalent.
- The color shall be clear or nominal white (i.e. unfiltered or clear filtered white light).
- The maximum pulse duration shall be two-tenths of one second with a maximum duty cycle of 40%. (The pulse duration is defined as the time interval between initial and final points of 10% of max signal)
- The intensity shall be a minimum of 75 candela.
- The flash rate shall be a minimum of 1 Hz and a maximum of 3 Hz.
- The appliance shall be placed 80" above the highest floor level within the space or 6" below the ceiling, whichever is lower.
- In general, no place in any room or space shall be more than 50' from the signal (measured in a horizontal plane).
 - In large rooms and spaces exceeding 100' across, without obstructions 6' above the finished floor, such as auditoriums, devices may be placed around the perimeter, spaced a maximum 100' apart, in lieu of suspending appliances from the ceiling.
- No place in common corridors or hallways shall be more than 50' from the signal.

4.30 – SIGNAGE

TAS SECTIONS 4.1.2(7), 4.1.3(16)(a) – WHERE APPLICABLE

- A. Signs which designate permanent rooms and spaces shall comply with the requirements listed below for:

- Raised and Braille Characters, and Pictograms

- Finish and Contrast

Mounting Location and Height

TAS SECTIONS 4.1.2(7), 4.1.3(16)(b) – WHERE APPLICABLE

- A. Signs which provide direction to, or information about, functional spaces of the building shall comply with the requirements listed below for:

- Character Proportion

- Character Height

- Finish and Contrast

- Exception: Building directories, menus, and all other signs which are temporary are not required to comply.

TAS SECTION 4.1.2(7) – WHERE APPLICABLE

- A. Element and spaces of accessible facilities which shall be identified by the International Symbol of Accessibility are:

- Parking spaces designated as reserved for persons with disabilities.
- Accessible passenger loading zones.
- Accessible entrances when not all are accessible (inaccessible entrances shall have directional signage to indicate route to nearest accessible entrance).
- Accessible toilet and bathing facilities when not all are accessible.

TAS SECTION 4.30.2 – CHARACTER PROPORTION (REFERENCE DETAIL 16.2)

- A. Letters and numbers on signs shall have a width-to-height ratio between 3.5 and 1:1, and a stroke-width-to-height ratio between 1:5 and 1:10.

TAS SECTION 4.30.3 – OVERHEAD SIGNS

- A. Characters and numbers on overhead signs shall be sized according to the viewing distance from which they are to be read.

- For signs higher than 80" above the finished floor, character size shall be 3" minimum.
- The minimum height is measured using an upper case X.
- Lower case letters are permitted.

TAS SECTION 4.30.4 – RAISED AND BRAILLE CHARACTERS AND PICTOGRAMS

- A. Letter and numerals shall be raised 1/32", upper case, sans serif and shall be accompanied by grade 2 Braille.

- Raised character height: 5/8" minimum, 2" high maximum.
- Pictograms shall be accompanied by the equivalent verbal description placed directly below the pictogram.
- The border dimension of the pictogram shall be 6" minimum.

TAS SECTION 4.30.5 – FINISH AND CONTRAST

- A. The character and background of the signs shall be eggshell, matte, or other non-gloss finish. Characters and symbols shall contrast with their background (either light characters on a dark background or dark characters on a light background).

TAS SECTION 4.30.6 – MOUNTING LOCATION AND HEIGHT (REFERENCE DETAIL 16.3)

- A. Where permanent identification is provided for rooms and spaces, signs shall be installed on the wall adjacent to the latch side of the door.
- B. Where there is no wall space to the latch side of the door, including at double-leaf doors, signs shall be placed on the nearest adjacent wall.
- C. Mounting height shall be 60" above the finished floor to the centerline of the sign.
- D. Mounting location for such signage shall be so that a person may approach within 3' of signage without encountering protruding objects or standing within the swing of a door.



International Symbol of Accessibility

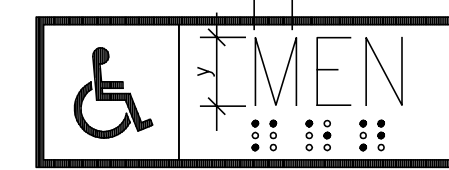

Letter & numbers on signs shall have a width to height ratio of between 3.5 & 1:1 and a stroke – width to height ratio between 1:5 & 1:10. Letters and numbers shall be raised 1/32", upper case, sans serif or simple serif type and shall be accompanied with grade 2 Braille, raised characters shall be at least 5/8" high, but no higher than 2".

Detail 16.1

Detail 16.2

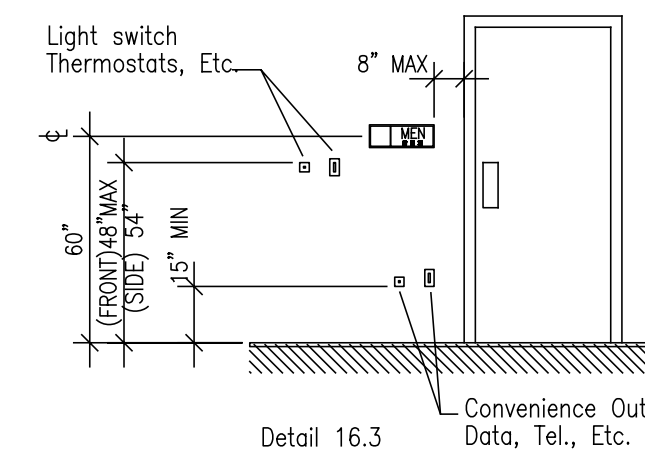

Detail 16.3

4.31 – PUBLIC TELEPHONES

TAS SECTION 4.1.3(17)(a) – WHERE APPLICABLE

- A. If public pay telephones, public closed circuit telephones, or other public telephones if provided, then they shall comply with this section in the quantities below:

- If one or more single unit of a type of public telephone is provided on a floor, then at least one of those phones shall comply with this section.

- If one bank (defined as two or more adjacent public telephones, often installed as a unit) of a type of telephone is provided on a floor, then at least one of the telephones at the bank shall comply with this section.
- If two or more banks of a type of public telephone are provided on a floor, then at least one telephone per bank shall comply with this section. The accessible unit may be installed as a single unit in proximity (either visible or with signage) to the bank. At least one public telephone per floor shall meet the requirements for a forward reach telephone.

Additional public telephones may be installed at any height.

Unless otherwise specified, accessible telephones may be either forward or side reach telephones.

TAS SECTION 4.1.3(17)(b) – WHERE APPLICABLE

- A. All telephones required to be accessible shall be equipped with a volume control.
- B. In addition, 25%, but never less than one, of all other public telephones provided shall be equipped with a volume control and shall be dispersed all type of telephones, including closed circuit telephones, throughout the building or facility.

- C. Signage displaying the International Symbol of Access for Hearing Loss shall be provided at each telephone equipped with a volume control.

TAS SECTION 51.3 – MOUNTING HEIGHT (REFERENCE DETAIL 17.1)

- A. The highest operable part of the telephone shall be 48" maximum above the floor where a forward reach is required, and 54" maximum where a side reach is required.
- B. If the forward reach is over an obstruction (with knee space equal to or greater than reach distance) 20"–25" deep the maximum height shall be 44", if the obstruction is less than 20", maximum height shall be 48".
- C. Maximum height shall be 46" for side reach over an obstruction 34" maximum high and 24" maximum deep.

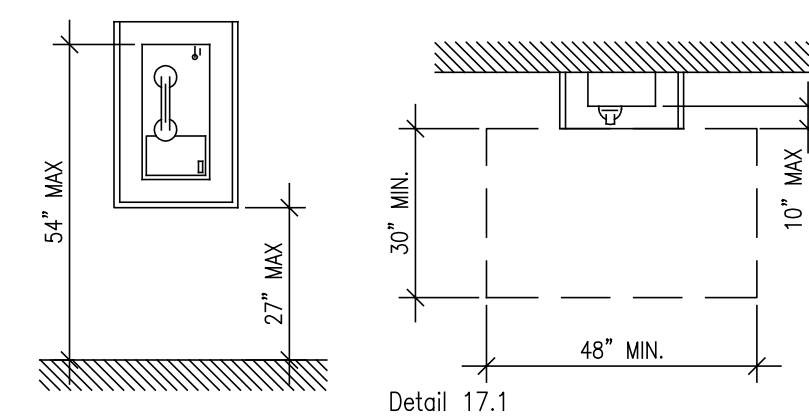

Detail 17.1

4.32 – SEATING AND TABLES

TAS SECTION 4.32.2 – SEATING

- A. If seating spaces for people in wheelchairs are provided at fixed tables or counters, clear floor space of 30" x 48" shall be provided. Floor space shall not overlap required knee space by more than 19".

TAS SECTION 4.32.3 – KNEE SPACE

- B. If seating for people in wheelchairs is provided at fixed tables or counters, knee space at least 27" high, 30" wide and 19" deep shall be provided.

TAS SECTION 4.32.4 – HEIGHT OF TABLES OR COUNTER

- C. The tops of accessible tables and counters shall be 28" minimum, and 34" maximum, above the finished floor.

4.34 – AUTOMATIC TELLER MACHINES

TAS SECTIONS 4.34.2 – CLEAR FLOOR SPACE

- A. Floor space shall comply with 4.2.4 to allow a forward, parallel approach or both.

TAS SECTIONS 4.34.3 – REACH RANGES

- A. Forward approach only: controls within forward approach specified in 4.2.5.
- B. Parallel approach: controls within unobstructed reach range from clear floor space at protrusion of teller machine surround per table as follows:

Reach Dp. (inches)	Max. Ht. (inches)	Reach Dp. (inches)	Max. Ht. (inches)	Reach Dp. (inches)	Max. Ht. (inches)
10 or less	54	15	51	20	48 1/2
11	53 1/2	16	50 1/2	21	47 1/2
12	53	17	50	22	47
13	52 1/2	18	49 1/2	23	46 1/2
14	51 1/2	19	49	24	46

Note: above does not apply to drive up machines.

4.35 – DRESSING AND FITTING ROOMS

TAS SECTIONS 4.35.4 – BENCH

- A. Every accessible dressing room shall have a 24"x 48" bench fixed to the wall along the larger dimension. The bench shall be mounted 17" to 19" above the finish floor.

TAS SECTIONS 4.35.5 – MIRROR

- A. A full-length mirror, measuring at least 18" wide by 54" high, shall be mounted in a position affording a view to a person on the bench as well as to a person in a standing position.

CISNEROS DESIGN STUDIO, ARCHITECTS LLC

4621 Montrose Blvd. Suite B220 Houston, Texas 77006
(PH) 713-520-7745 (FAX) 713-520-8894

Copyright 2011 CISNEROS DESIGN STUDIO, ARCHITECTS, LLC. All rights reserved. This document is the property of the Architect. It is to be used only for the project for which it is prepared. No part of this document may be reproduced, stored in a retrieval system, or transmitted in any form or by any means, electronic, mechanical, photocopying, recording, or by any information storage and retrieval system, without the prior written permission of the Architect. The Architect, its employees, agents, and subcontractors shall not be held responsible for construction means, methods, techniques, sequences or procedures, or for safety precautions and programs in connection with the project.