

A **FOODSERVICE PLUMBING PLAN**
FS1.2 SCALE: 1/4"=1'-0"

VERIFY WITH ARCHITECTS
 PLANS FOR EXACT
 LOCATION.

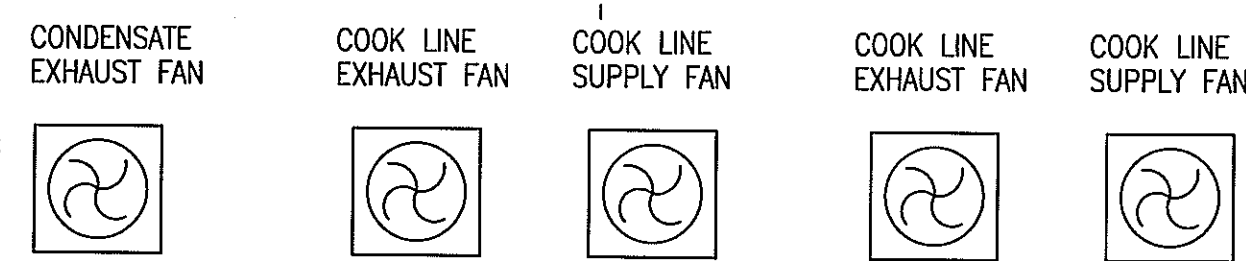

PLUMBING SYMBOLS

○	HW	HOT WATER	○	G	GAS SUPPLY
○	CW	COLD WATER	○	IW	INDIRECT WASTE (EXTEND TO F.D.)
○	HTW	180 F HOT WATER	○	FFD	FUNNEL FLOOR DRAIN
○	CWS	CHILLED WATER	●	PS	PIPE SLEEVE
○	SS	STEAM SUPPLY	○	AFF	ABOVE FINISHED FLOOR
○	CR	CONDENSATE RETURN	○	ST	STUB UP/OUT
○	DR	DRAIN	○	BTC	BRANCH TO CONN. ON EQUIP
○	FD	FLOOR DRAIN	○	DFA	DROP FROM ABOVE
○	FS	FLOOR SINK			

TRENCH/LINER DETAIL

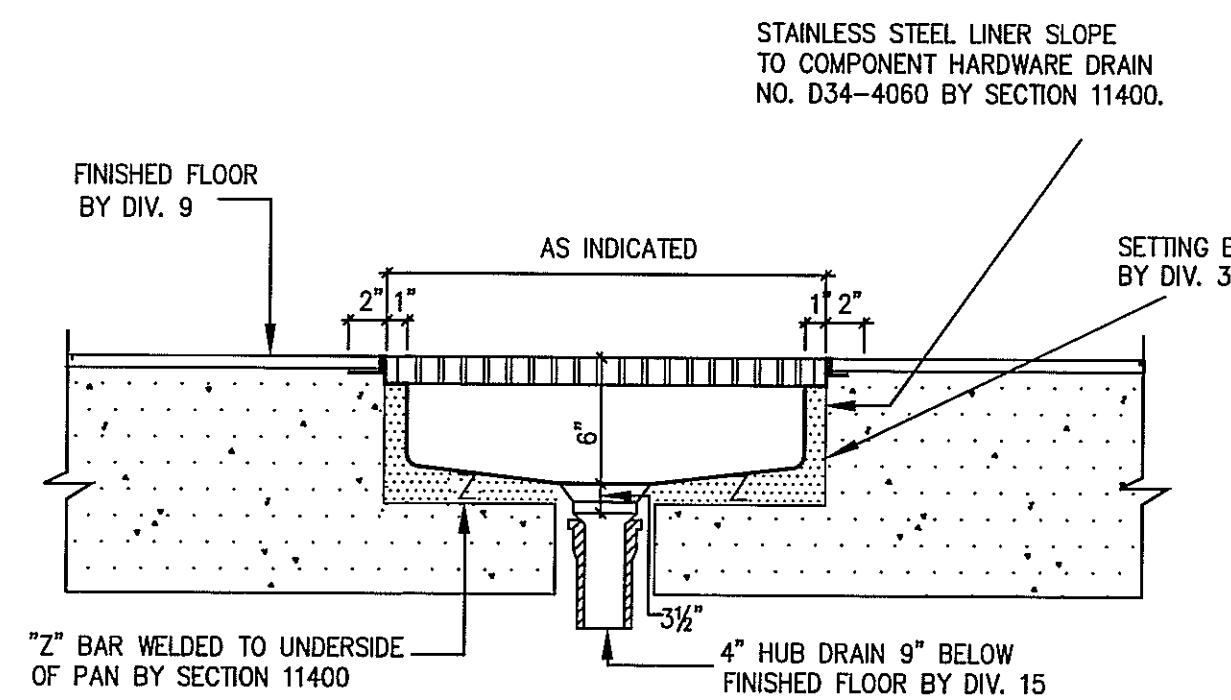

PLUMBING / MECHANICAL NOTES

- DO NOT ROUGH-IN FROM THIS DRAWING. REFER TO CONTRACTORS DIMENSIONED DRAWINGS.
- DIMENSIONS INDICATED ARE TO BE VERIFIED BY CONTRACTOR AND ADJUSTED AS REQUIRED BY EQUIPMENT OR FIELD CONDITIONS.
- ACCESSORIES AND FITTINGS PROVIDED LOOSE WITH FOODSERVICE EQUIPMENT BY SECTION 11400. FIELD INSTALLED BY DIVISION 15
- SERVICE SINK BY DIVISION 15.
- HAND WASH LAVATORY WITH SOAP AND TOWEL DISPENSER BY DIVISION 15.
- FLUSHING OUT OF ALL PIPING AND DRAINAGE SYSTEMS PRIOR TO CONNECTION OF FOODSERVICE EQUIPMENT BY DIVISION 15.
- FIRE HOSE CABINET AND SPRINKLER SYSTEMS BY DIVISION 15.
- VENTILATE WAREWASH AND UTENSIL WASH ROOMS IN ADDITION TO MACHINE REQUIREMENTS INDICATED ON MECHANICAL CONNECTIONS DRAWINGS.

REFER THE FOLLOWING NOTES TO "HEX" SYMBOLS INDICATED ON "FS" PLUMB / ELECT DRAWINGS:

- 1" MIN. COPPER DRAIN LINE PREPARED FROM EQUIPMENT TO UTILITY COMPARTMENT BY SECTION 11400. FINAL CONNECTIONS TO HUB DRAIN, FUNNEL FLOOR DRAIN OR FLOOR SINK BY DIVISION 15.
- 1" MIN. CONDENSATE DRAIN LINE FROM EVAPORATOR COIL TO AIR-GAP DRAIN / VALVE BOX OR FUNNEL FLOOR DRAIN BY SECTION 11400. INSTALL INSULATION AND HEATER CABLE ON DRAIN LINE AT COOLER SUBJECT TO FREEZING. FINAL CONNECTION TO FUNNEL FLOOR DRAIN BY DIVISION 15.
- F.S.E.C. TO COORDINATE LOCATION, ROUTING AND SUPPORT OF DRAIN LINE PIPING FOR SINKS, ETC., WITHIN OPEN BASE FIXTURES. HORIZONTAL PIPING MUST BE 6" CLEAR AFF, TURNED DOWN TO 1" AFF OVER OPENING IN FLOOR SINK GRATE. DO NOT ATTACH DRAIN PIPING TO FLOOR OR WALLS. HANGERS AND BRACKETS FOR RIGID ATTACHMENT OF DRAIN PIPING TO FIXTURE BASE BY DIV. 15, COORDINATED BY SECTION 11400.
- SECTION 11400 TO PROVIDE GAS SHUT-OFF VALVES WITH EXHAUST HOOD FIRE EXTINGUISHING SYSTEM FOR INSTALLATION AT CEILING BY DIVISION 15/16.
- HUB DRAIN - RE: "TRENCH / LINER" DETAIL.
- 1-1/2" COPPER DRAIN FROM STEAMER BY DIVISION 15.
- 6" DIAMETER EMT CONDUIT ABOVE CEILING AND STUB OUT OF WALL AT 12" AFF TO AND BETWEEN THE BEVERAGE COUNTER FOR BEVERAGE LINES. EMPTY EMT CONDUIT WITH WIDE SWEEP BENDS - 24" MIN RADIUS AND PULL WIRES FURNISHED AND INSTALLED BY DIVISION 16.

REFER TO FS1.01 FOR
 PLUMBING SCHEDULE

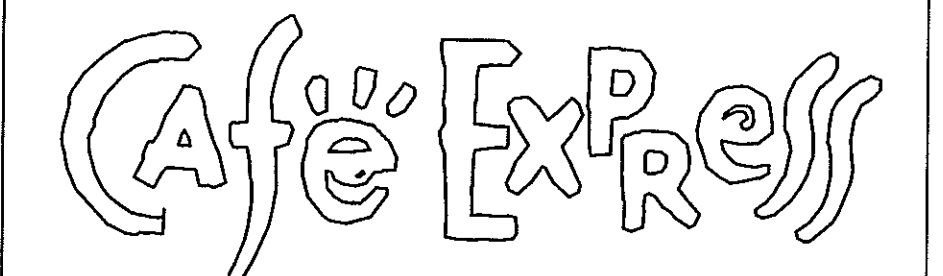

3418 NORTH LAMAR BOULEVARD
 AUSTIN, TEXAS 78705

Gensler

711 Louisiana
 Suite 300
 Houston, Texas 77002
 Tel: 713.844.0000
 Fax: 713.844.0001

ISI.
Food Service Equipment

640 WEST 6TH STREET
 HOUSTON, TX 77007
 PHONE: 713861-4455

Issue	Date & Issue Description	By	Check
	12/23/09	ISI	Lee C.
ISSUE FOR PERMIT, PRICING & CONSTRUCTION			
	01/11/10	ISI	Lee C.
HEALTH DEPARTMENT COMMENTS			

Seal/Signature

Project Name
 CAFE EXPRESS / AUSTIN

Project Number
 02.6924.001
 CAD File Name

Description

Scale

**FOODSERVICE EQUIPMENT
 PLUMBING PLAN**

FS1.2

©2009 Gensler