

ISSUE
02/28/12
ISSUED FOR PERMIT
AND PRICING

HARRELL

ARCHITECTS, LP

9575 Katy Fwy. #200
Houston, Texas 77024
Tel: 713.222.7071
Fax: 713.222.7072

CONSULTANTS
Hilbink & Associates, Inc.
11000 Katy Fwy., Suite 510
Houston, Texas 77024
Tel: 281.466.1100
www.hilbink.com
Contact: Ken Odom 832.645.0368



Cafe Express Restaurant
PROJECT ADDRESS
1111 Eldridge Parkway #100
Houston, Texas 77077

PROJECT NUMBER
11052
SHEET NAME
MECHANICAL
DETAILS
SHEET NUMBER

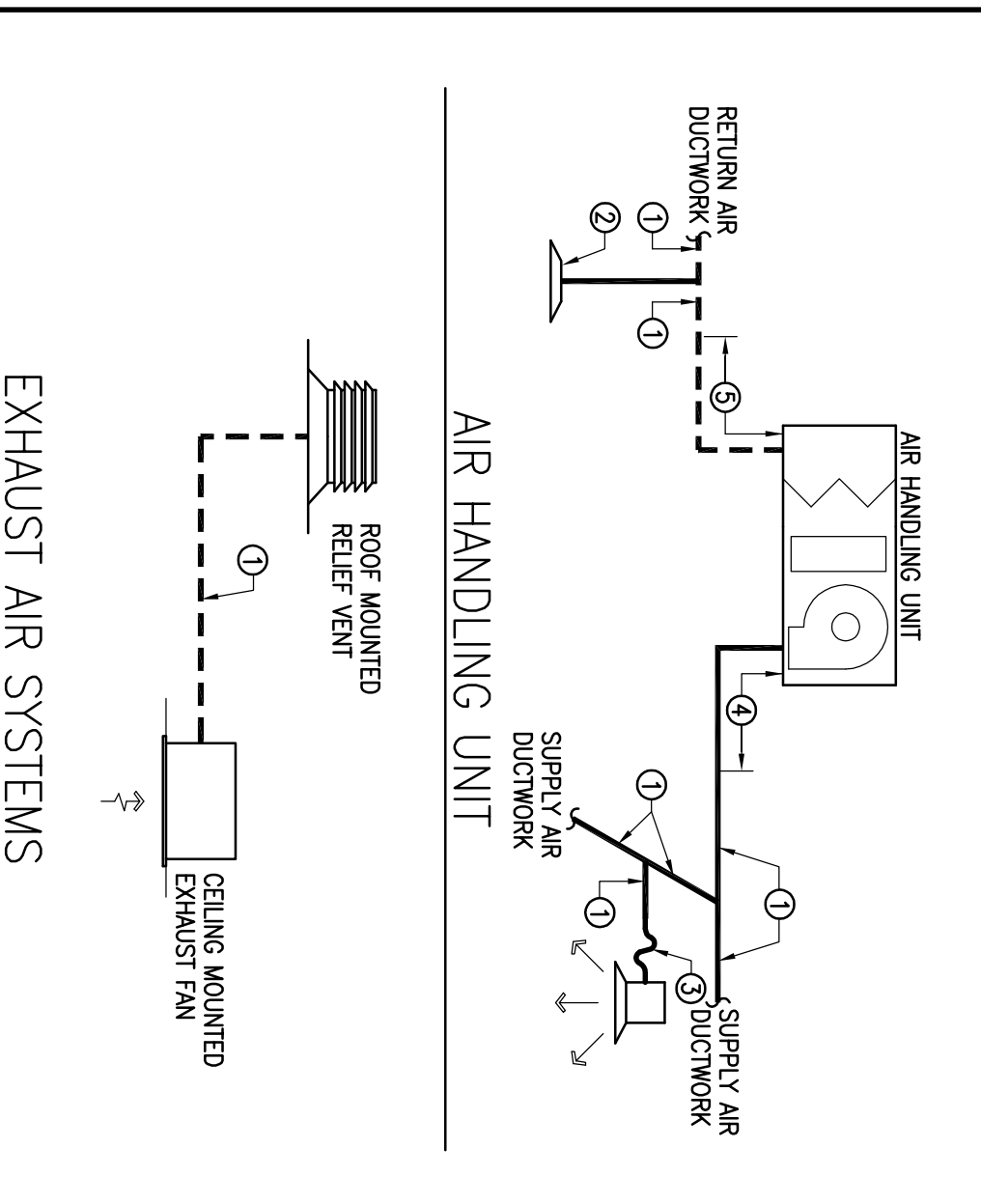
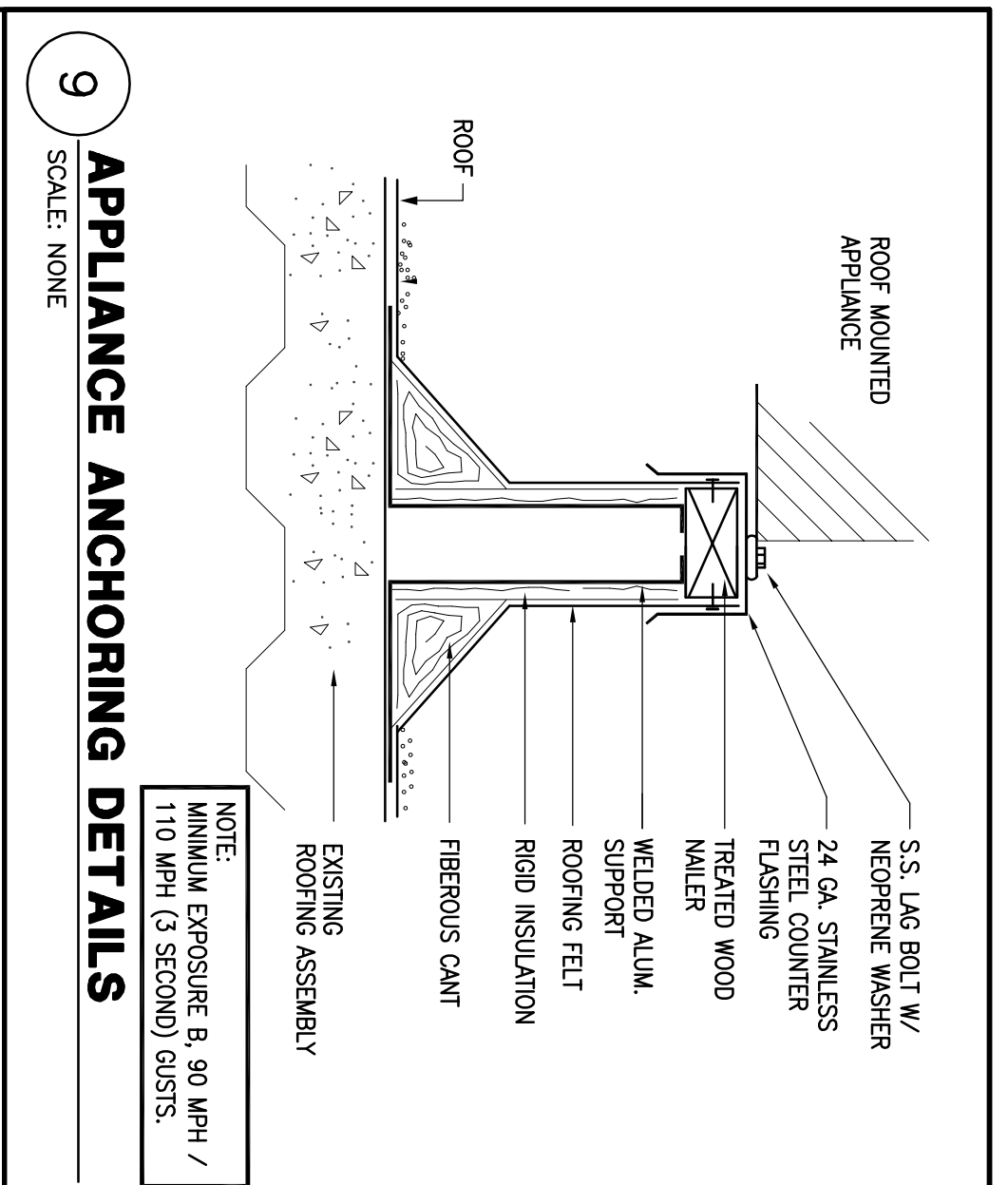
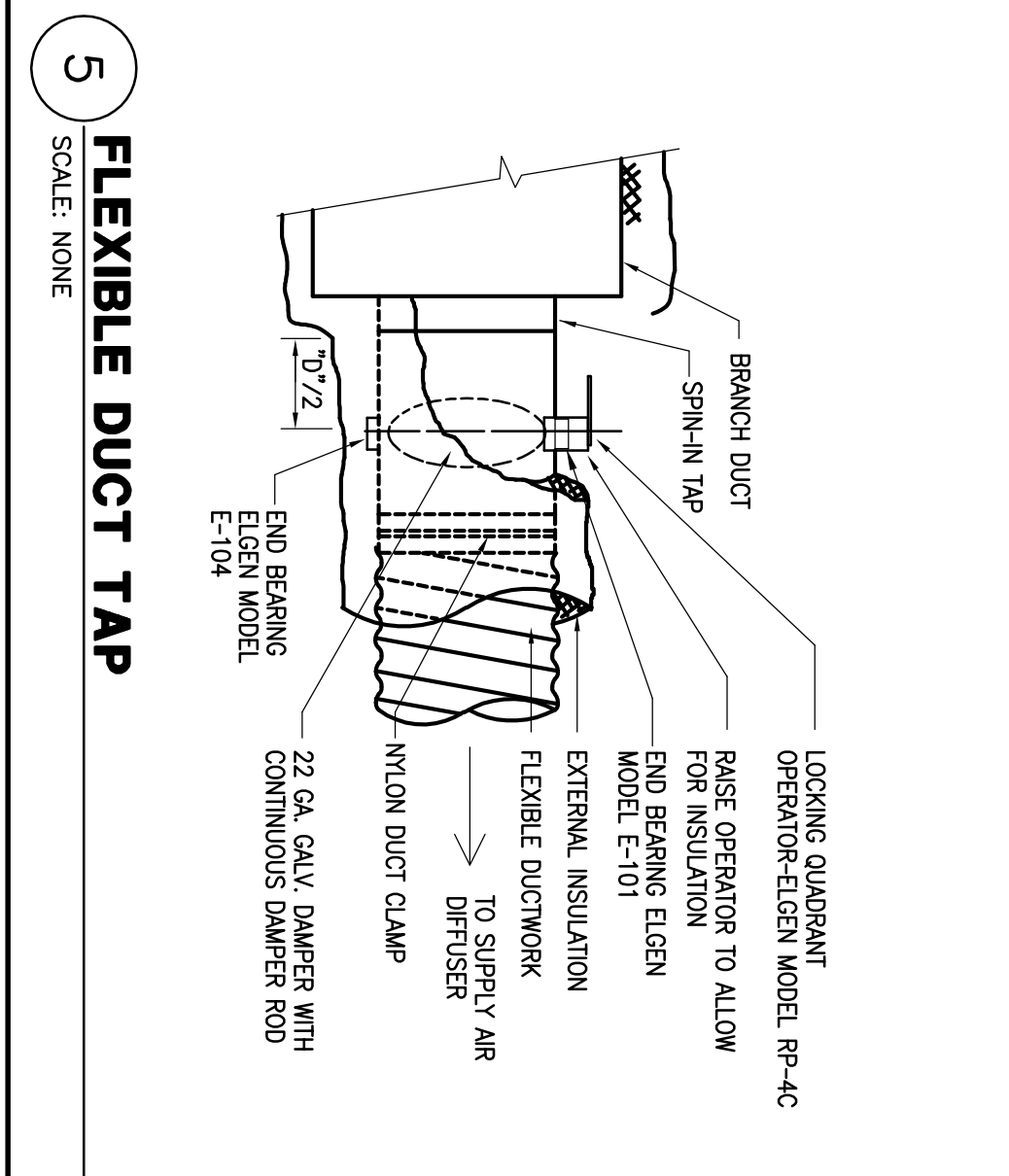
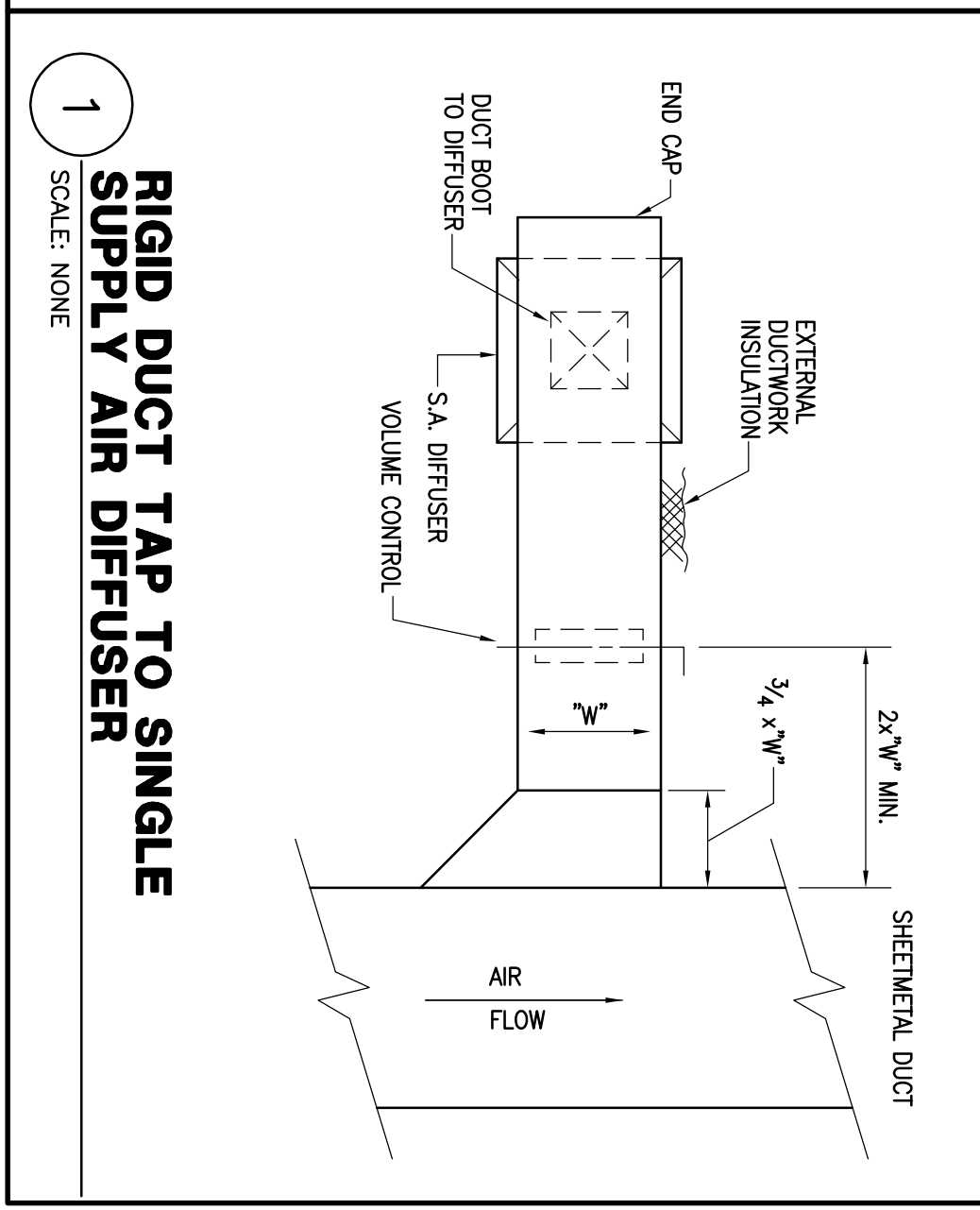
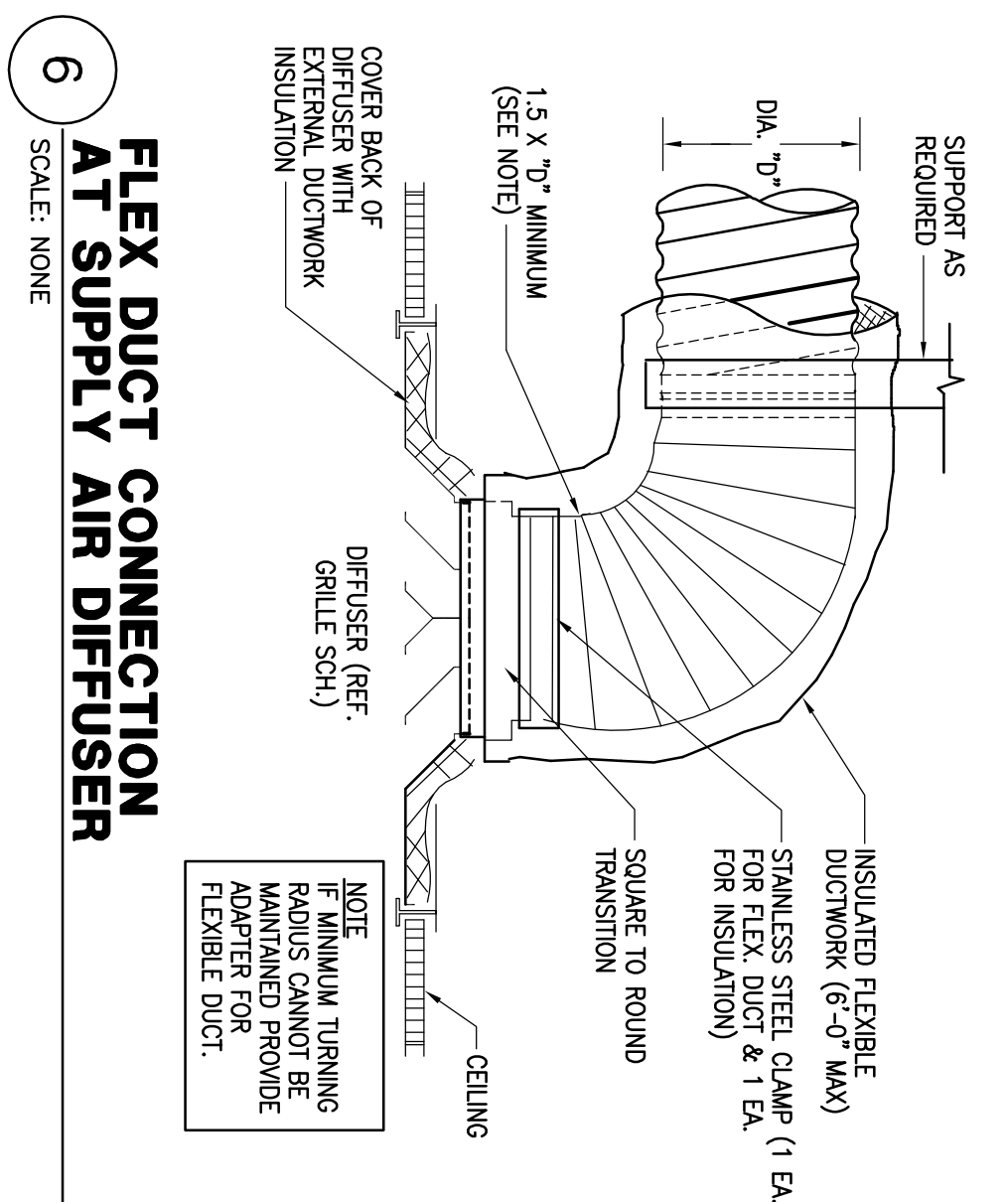
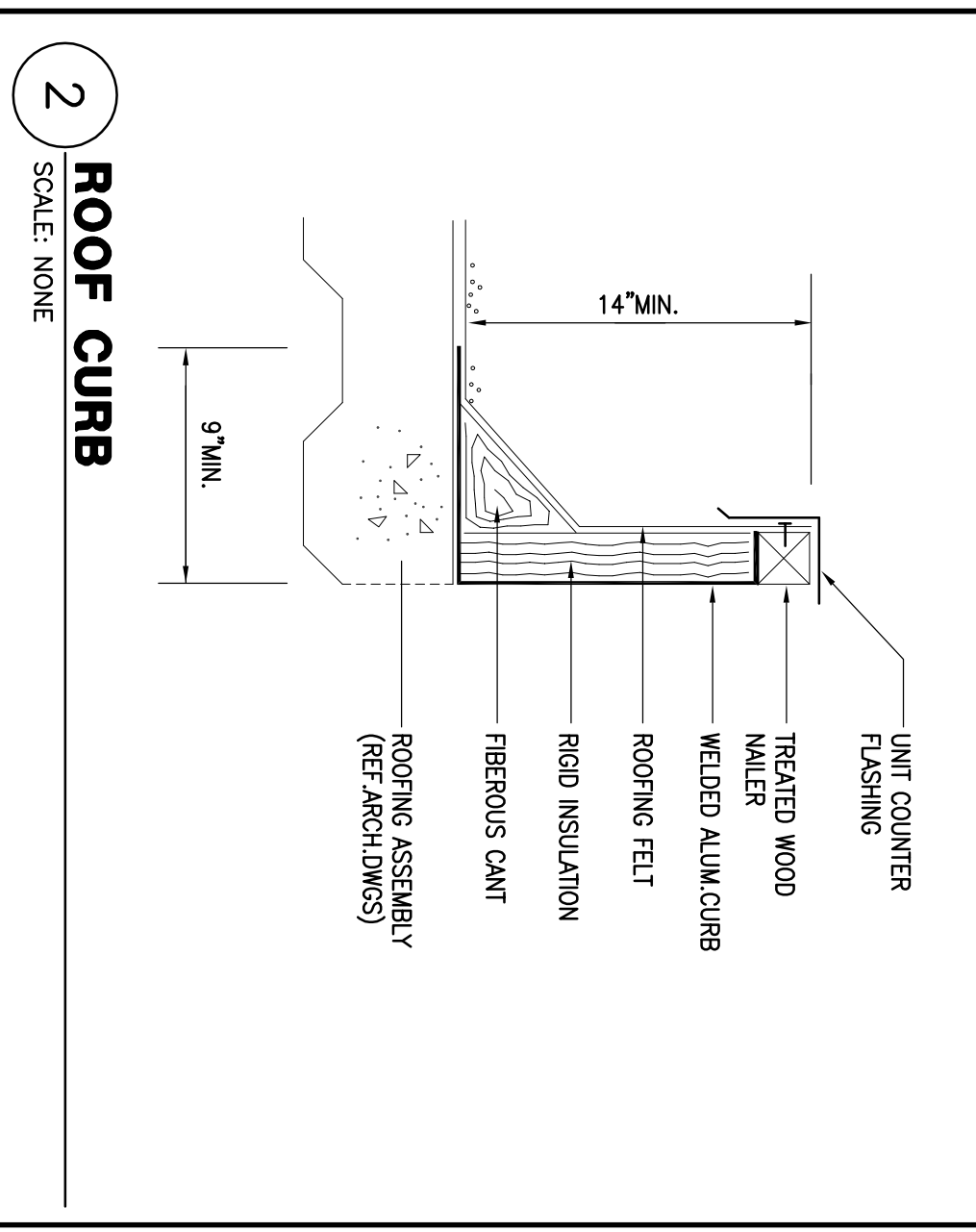
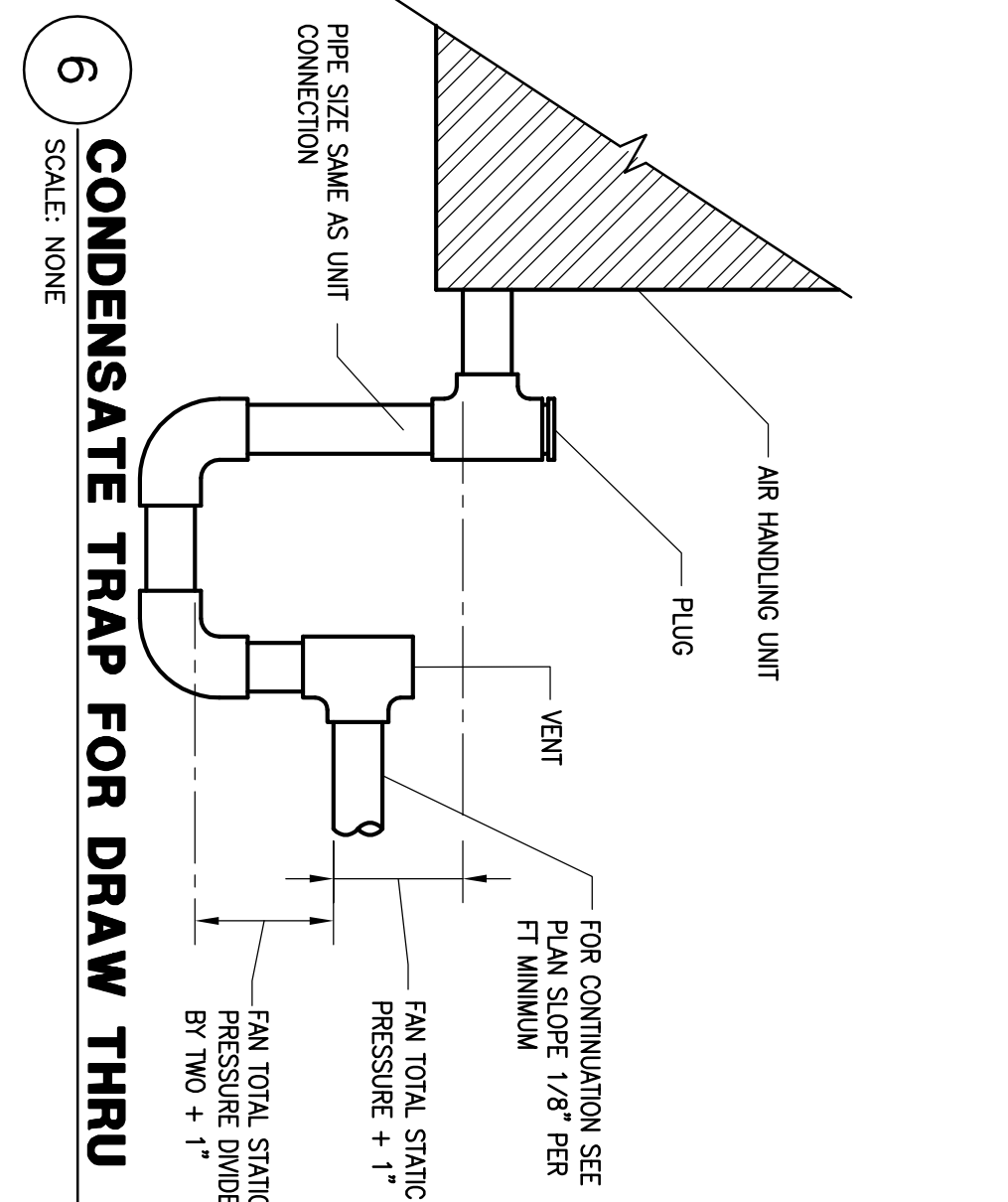
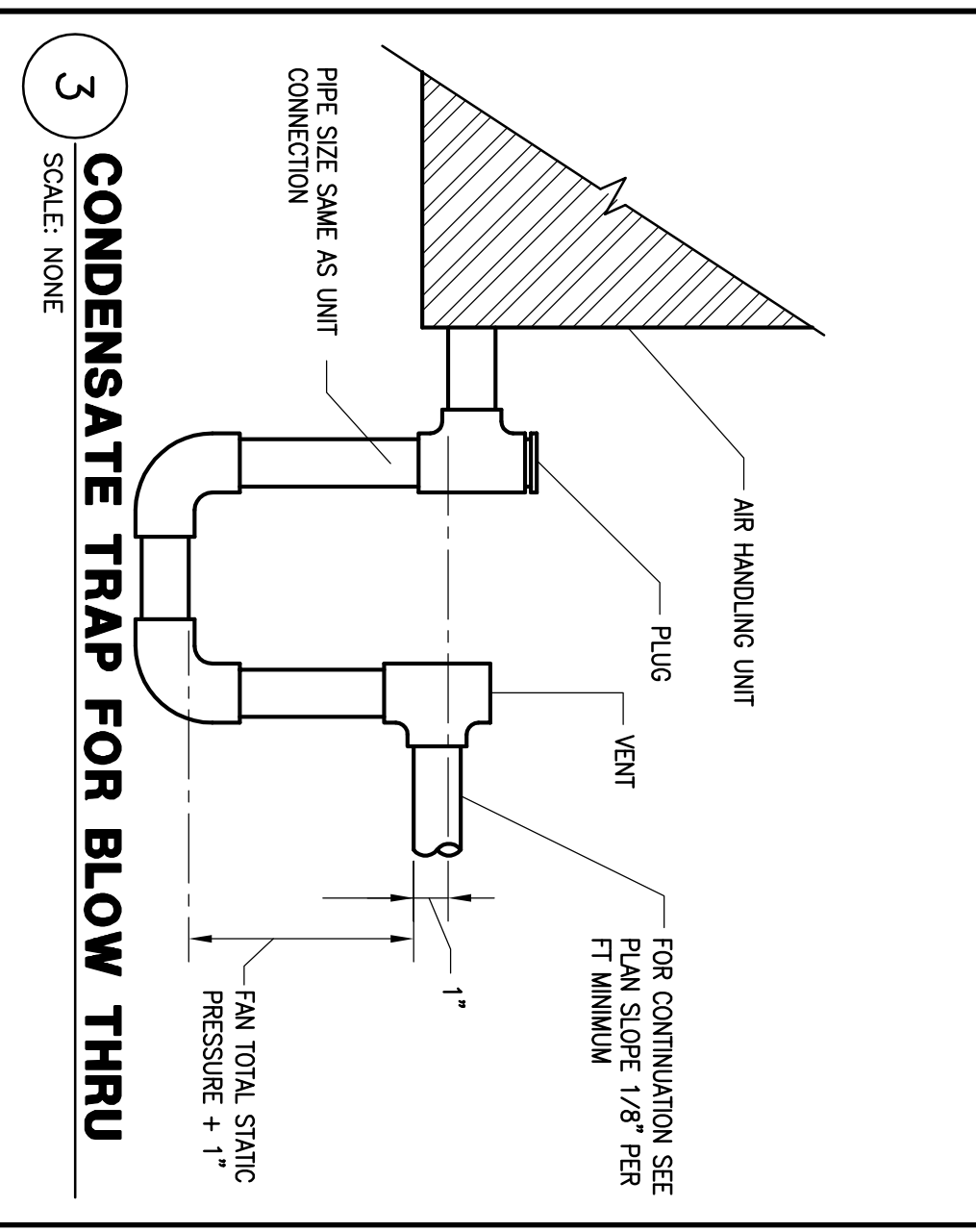
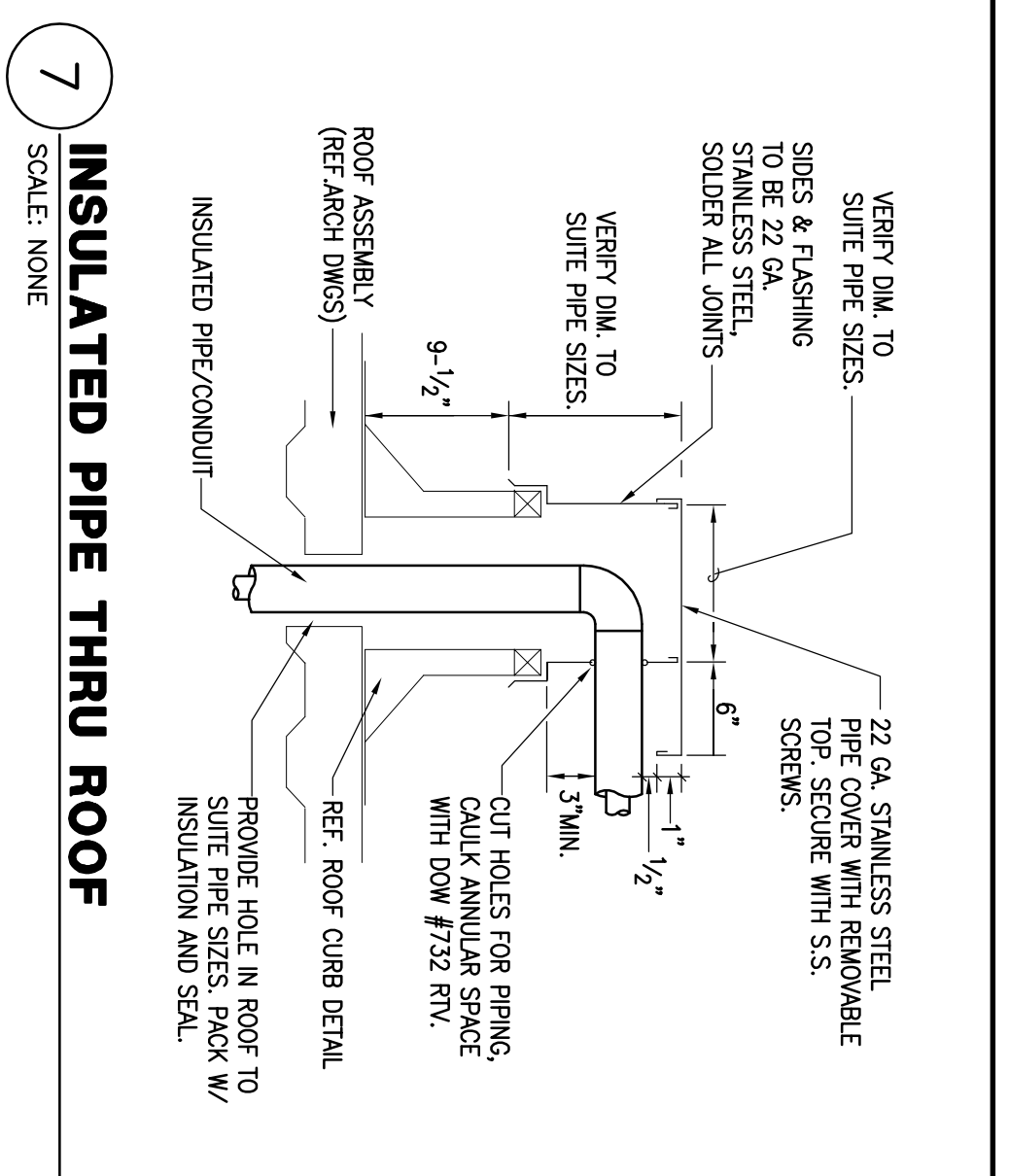
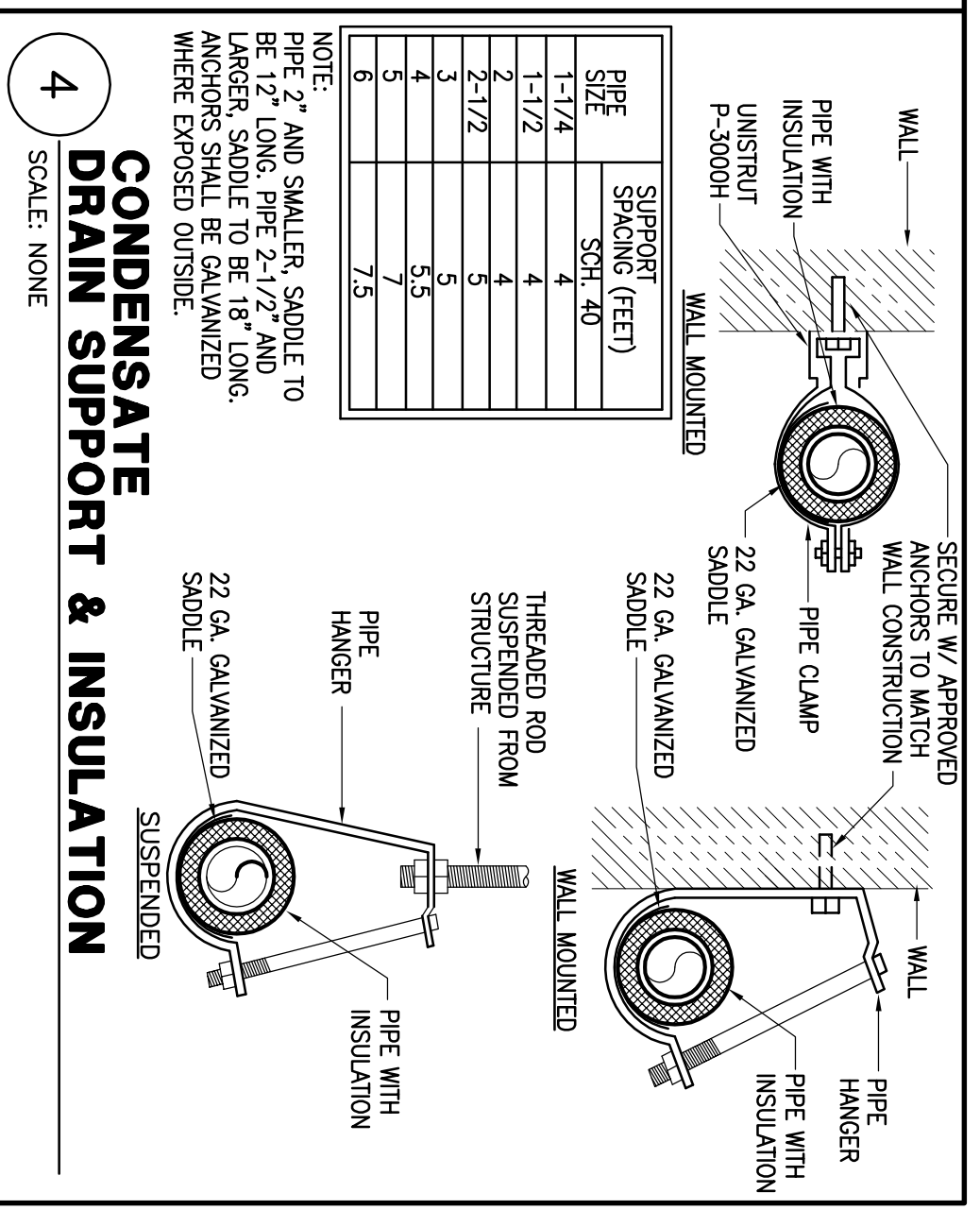

- NOTES
- 1 SHEETMETAL DUCTWORK WITH EXTERNAL DUCTWORK INSULATION AS SPECIFIED.
 - 2 EXTERNAL INSULATION (MIN. R-4) ON BACK PAN OF RETURN AIR GRILLE.
 - 3 FLEXIBLE DUCTWORK WITH EXTERNAL DUCTWORK INSULATION AS SPECIFIED.
 - 4 SHEETMETAL DUCTWORK WITH EXTERNAL DUCTWORK INSULATION AS SPECIFIED AND DOWNSTREAM.
 - 5 SHEETMETAL DUCTWORK WITH EXTERNAL DUCTWORK INSULATION AS SPECIFIED AND MIN. THICK 1-1/2 LB LINER TO 0' UPSTREAM OF ROOF TOP UNIT TO RETURN AIR INLET.